

# Ultrasonic Flow Meter for Air TRX-[Nominal Diameter] [Power Supply Specification]- [Kind of Gas]/5P Operation Manual



# Ultrasonic Flow Meter for Air

(TRX[Nominal Diameter] [Power Supply Specification]-[Kind of Gas]/5P)

## Operation Manual

### Table of contents

○ Preface/Request	
○ Outline of product	
○ Important notice	
○ For safe and proper use	
1. Introduction.....	1
1-1 Confirmation of package contents .....	1
1-2 Name of each part .....	1
1-3 Flow of operation start .....	2
2. Settings .....	3
2-1 Standard factory delivery settings.....	3
2-2 Procedures to change settings .....	5
2-3 Details of setting items.....	10
3. Installation .....	15
4. Wiring connection.....	19
5. Operation.....	24
6. Display and output under aberrant states.....	24
7. Operation modes.....	27
8. Processes during power outages (external power supply specification: D, RS485 output specification: R) .....	30
9. Specifications .....	31
10. Dimension drawing.....	33
11. Troubleshooting.....	34
○ Warranty and after-sale service (valid only in Japan).....	37

## ○ Preface/Request

Thank you very much for purchasing the Ultrasonic Flow Meter for Air TRX[Nominal Diameter] [Power Supply Specification]-[Kind of Gas]/5P this time. Please be sure to read this Operation Manual to use this product correctly and safely and to prevent failures.

### Request

Please arrange for operators who actually use this product to know the context of this Operation Manual surely.

This Operation Manual becomes necessary for performing maintenance, too. Please keep the Manual in a safe place until this product is disposed of.

## ○ Outline of product

Nominal diameter	Power supply specification	Kind of gas
25	D: External power supply specification B: Built-in battery specification R: RS485 output specification	C: Factory-supplied air N: Nitrogen
32		
40		
50		
65		
80		

This flow meter is the ultrasonic flow meter for air and nitrogen capable of measuring the flow at pressure from the atmospheric pressure to less than 1 MPa. The flow meter is installed to pipes by screwing its taper pipe threads to the pipes or by being tightened between pipe flanges.

- Screw connection type (Taper pipe threads) applied models: TRX25, TRX32
- Wafer connection type (Installation between pipe flanges and by tightening with bolts) applied models: TRX40, TRX50, TRX65, TRX80







The flow meter satisfies the following standards.

- EN61326-1 : 2013 Table 2 (EMS)
- EN55011:2009+A1:2010 Group 1 Class A (EMI)

○ Important notice

To ensure the safe use of this flow meter and to prevent a failure or an unexpected situation, instructions to which attention must be paid are indicated with the following symbols.

**Structure of warning indications**

 <b>Danger</b>	Incorrect handling by failure to follow instructions with this sign may lead to imminent danger of death or serious injury.
 <b>Warning</b>	Incorrect handling by failure to follow instructions with this sign may lead to death or serious injury.
 <b>Note</b>	Incorrect handling by failure to follow instructions with this sign may lead to injury, properties loss (product damage, etc.), pecuniary loss, and/or punishment according to a penal regulation for violation of laws and ordinances.
	This symbol indicates that improper operation may result in an accident.
	This symbol indicates prohibited acts.
	This symbol indicates matters you should observe without fail.

## ○ For safe and proper use

### Precautions for use

 <b>Danger</b>	<ul style="list-style-type: none"> <li>⊘ 1. Do not use for applications that require safety, such as nuclear, railroad, aircraft, vehicle, playground equipment, etc.</li> <li>⊘ 2. Do not modify the product.</li> <li>⊘ 3. Do not use the product for foods, drinks, medical chemicals, etc., because it is not of sanitary specifications.</li> <li>⊘ 4. Do not use the product in the atmosphere of an inflammable gas, etc., because it is not of explosion-proof specifications.</li> </ul>
--	---

### Working environment and applicable fluid

 <b>Note</b>	<ul style="list-style-type: none"> <li>⊘ 1. Do not apply any fluid other than air (compressed air used in factories) or nitrogen to this flow meter. (The meter can be applied for nitrogen by factory setting before shipment from our factory.)</li> <li>ⓘ 2. Observe the temperature and humidity ranges (-10 to +60°C and 90%RH or lower) and pressure range (the atmospheric pressure to less than 1 MPa) in use.</li> <li>⊘ 3. Avoid usage in an ambient containing a corrosive gas (chlorine, hydrogen sulfide, etc.) and/or for an application to a fluid containing a corrosive gas.</li> <li>⊘ 4. This flow meter is not of a perfect waterproof structure (IP64). Do not install it at a place that may be submerged in water.</li> <li>ⓘ 5. Install the flow meter as far away from an electric noise source as possible. If it is installed near the electric noise source, ground the shield of the external connection cable.</li> <li>ⓘ 6. Ground the 0 V terminal without fail, and do not ground the 24 V(+) terminal. Because the cabinet is connected to SG (0 V), if the 24 V(+) terminal has been grounded, the + and - of the power supply is short-circuited through piping.</li> <li>7. The installation of a sunshade is recommended if the flow meter is exposed to direct sunlight.</li> </ul>
--	--



### Notes for operations

 <b>Note</b>	<ul style="list-style-type: none"> <li>1. This flow meter is not a specified measuring instrument defined in Japanese measurement law.</li> <li>ⓘ 2. When opening or closing a valve, open or close the valve not all at once but gradually. Opening or closing of the valve all at once may cause a failure of the flow meter if a pressure difference is occurring between the upstream side and downstream side of the valve.</li> </ul>
--	---



### Storage

 <b>Note</b>	<ul style="list-style-type: none"> <li>⊘ 1. Store the flow meter at a place away from fire and not exposed to direct sunlight.</li> <li>⊘ 2. Do not place any combustible material, inflammable substance and heating body in the periphery of the flow meter.</li> <li>ⓘ 3. Store this flow meter at a place which ambient temperature is -20 to +70°C and where no dew condensation occurs.</li> </ul>
--	--

### Piping

 <b>Warning</b>	<ul style="list-style-type: none"> <li>⊘ 1. Do not ride on this flow meter using it as a foothold.</li> <li>⊘ 2. Do not hold the display section of this flow meter.</li> </ul>
 <b>Note</b>	<ul style="list-style-type: none"> <li>1. In the case a flow-regulating valve, etc., that may cause turbulence of the flow is installed, its location must be on the downstream side of the flow meter.</li> <li>2. In the case of new piping, install the product after sufficient cleaning of the pipe(s).</li> <li>3. Vertical piping is recommended when mist, dust, etc. are contained in a large amount. In horizontal piping, install the flow meter in such a way that the display section faces upward.</li> <li>4. Do not install the product in locations where strong compressive force, tensile force, or load may be applied.</li> <li>5. Arrange piping so that the flow direction conforms to the direction of arrow indicated on the flow meter's body.</li> <li>6. Do not drop it or do not make it bumped. Do not apply excessive impact, either.</li> <li>7. When rotating the display section, do not apply a force in a direction other than the rotating direction.</li> <li>ⓘ 8. Keep hands off the ultrasonic sensors.</li> </ul>

### Wiring

 <b>Danger</b>	<ul style="list-style-type: none"> <li>ⓘ 1. When performing wiring work, follow the instructions in this Operation Manual.</li> <li>ⓘ 2. Use the product within the rating.</li> <li>⊘ 3. Do not use the product on a voltage exceeding permissible load.</li> </ul>
 <b>Note</b>	<ul style="list-style-type: none"> <li>1. Do not place the product's external connection cable together with or near to power supply line(s) or power line(s), etc.</li> <li>2. Electrical isolation of a remote counter (a receiver) from others is recommended.</li> <li>3. Do not apply an excessive tensile force to the external connection cable.</li> <li>4. Ensure that the cable tip is not soaked in water during wiring work, etc.</li> <li>ⓘ 5. When connecting the power supply wire of the external connection cable to an external power supply, be careful not to short-circuit it. Use an external power supply having a short-circuit protecting function.</li> <li>ⓘ 6. Be sure to perform the wiring work in a state that power supply from the external power supply is interrupted.</li> <li>⊘ 7. Do not perform operation and the wiring work with wet hands.</li> </ul>

### Disassembling and inspection

 <b>Note</b>	<ul style="list-style-type: none"> <li>⊘ 1. Do not disassemble this flow meter.</li> <li>2. Presence of fluid flow makes a pilot lamp flicker in a normal state. In the case of no flickering of the pilot lamp, contact our branch or sales office nearby.</li> <li>3. If mist and/or dust are contained in a large amount, disconnect the flow meter periodically to check for the presence of dirt etc., and remove it as necessary.</li> <li>ⓘ 4. Be careful not to touch the ultrasonic sensors during inspection.</li> </ul>
--	--

### Disposal

 <b>Warning</b>	<ul style="list-style-type: none"> <li>ⓘ 1. Since the flow meter is made by putting metals and resin parts together, it must be discarded as industrial waste.</li> </ul>
---	---

# 1. Introduction

## 1-1 Confirmation of package contents

Upon delivery of the product, confirm that the following items are contained in the package:

Name	Quantity	Remark
Ultrasonic flow meter	1	
Centering collars	4	For its use, refer to 3. Installation (page 15). Accessory of the wafer connection type.
M4 hexagonal wrench	1	The wrench is to be used to untighten and tighten the set screw when changing direction of the display section and to press the back center button (SW3).
Flange gasket	2	Accessory of the wafer connection type.
Operation manual	1	
Bolt set (Bolts/nuts/plain washes)	1 set	The bolts/nuts/plain washers are put into a bag in a set of required quantities. Accessory of the wafer connection type.
External connection cable	1	[External power supply] 5m • Standard accessory, 20m • Option part [RS485 output] 5m • Standard accessory, 20m • Option part [Built-in battery] 5m • Option part, 20m • Option part



FLOW METER

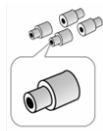

CENTERING COLLARS



M4 HEXAGONAL WRENCH



FLANGE GASKET

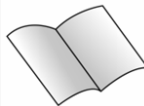

OPERATION MANUAL



BOLT SET



EXTERNAL CONNECTION CABLE

## 1-2 Name of each part

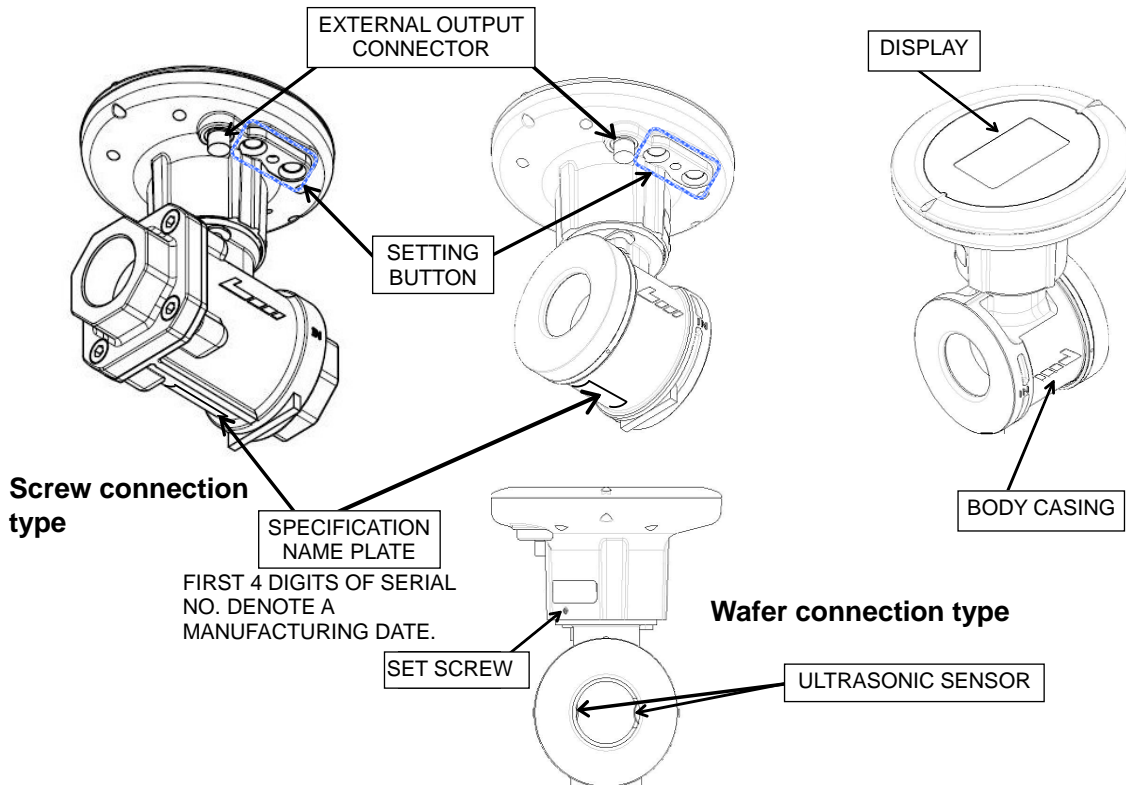

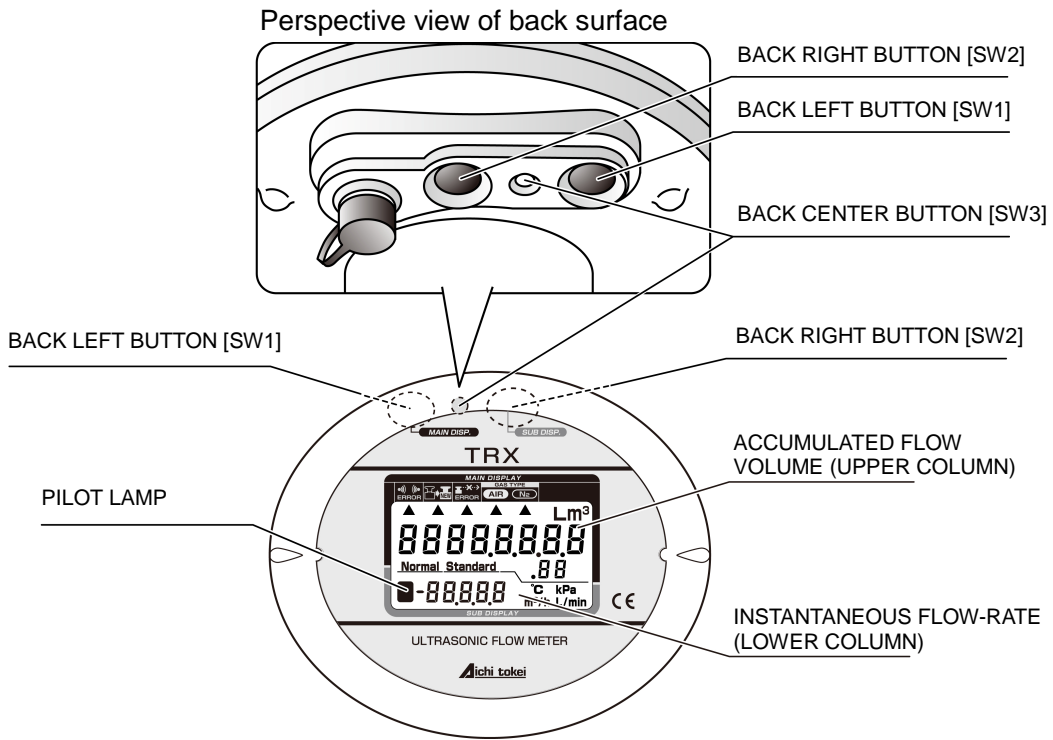

### 1-3 Flow of operation start

The basic flow up to the start of operation is as follows.

Although the settings can be made after installation as well, it is recommended to perform the settings prior to installation.

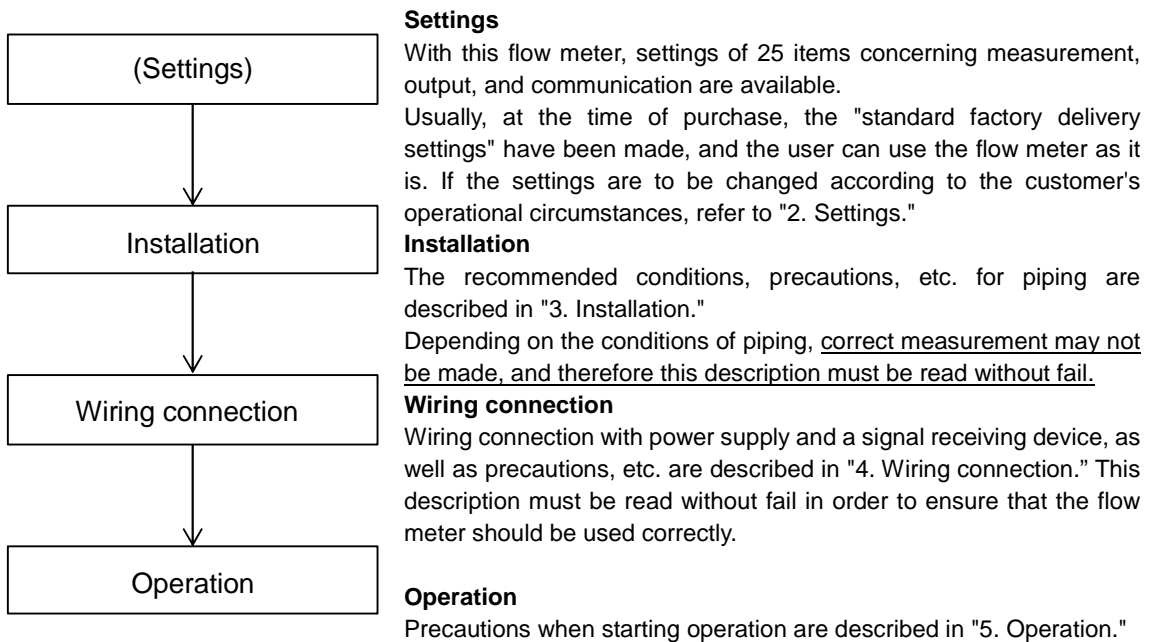



## 2. Settings

### 2-1 Standard factory delivery settings

With this flow meter, settings of 25 items concerning measurement, output, and communication are available. (Table 2-1)

At the time of purchase, the "standard factory delivery settings" have been made, and the user can use the flow meter as it is.

When changing the standard factory delivery settings, perform operation according to the procedures described on pages 5 through 7.

Hereafter, built-in battery specification is denoted as B, external power supply specification as D, and RS485 output specification as R.

Table 2-1 Setting items and standard factory delivery settings

Panel display	Corresponding setting item	Scope of setting	Standard factory delivery settings		
			B	D	R
F1	Display · Output	Forward flow, forward and reverse flow	Forward flow		
F2	Analog output full scale flow-rate	0 to 99999 [m <sup>3</sup> /h]	25A:300 32A:600 40A:700 50A:1200 65A:2000 80A:2500		
F3	State of contact output	Normal open, Normal close	Normal open		
F4*1	Contact output	Reverse flow pulse, upper/lower limit flow-rate alarm, error alarm, electronic statement output	Upper/lower limit flow-rate alarm	/	
F5	Lower limit alarm flow-rate	-59999 to 59999 [m <sup>3</sup> /h]	0 [m <sup>3</sup> /h]		
F6	Upper limit alarm flow-rate	-59999 to 59999 [m <sup>3</sup> /h]	59999 [m <sup>3</sup> /h]		
F7	Alarm judgment value hysteresis width	0 to 9999 [m <sup>3</sup> /h]	0 [m <sup>3</sup> /h]		
F8	Flow-rate moving average number of times	01, 02, 04, 08, 16, 32, 64 [times]	04 [times]		
F9	Output pulse unit	Refer to Table 2-2.	100 [L]		
F10	Pulse output method	Duty or one shot 50, 100, 125, 250, 500 [ms]	Duty		
F11	Flow-value conversion selection	Yes (Normal), Yes (Standard), No conversion	Yes (Normal)		
F12	Standard conversion temperature	-10 to 60 [°C]	20 [°C]		
F13	Test mode time selection	3, 60, Unlimited [minutes]	3		
F14	Fluid selection	Air, Nitrogen	The kind of gas is set as the kind specified at the time of order.		
F15	Current output correlation value	Instantaneous flow-rate, pressure, temperature	Instantaneous flow-rate		

Panel display	Corresponding setting item	Scope of setting	Standard factory delivery settings		
			B	D	R
F16	Low flow cutoff flow-rate	$0 \leq \text{Setting value} \leq Q_{\min}^{*4}$ [m <sup>3</sup> /h]	25A:0.1 32A:0.2 40A:0.2 50A:0.4 65A:0.6 80A:0.8		
F17	Atmospheric pressure of the working environment	000.0 to 999.9 [kPa]	101.3		
F18	With or without pressure value averaging	With (10 times), without (1 time)	With (10 times)		
F19 <sup>*2</sup>	RTU address	001 to 247			001
F20 <sup>*2</sup>	RS485 communication bit rate	9600, 19200, 38400, 57600, 115200 [bps]			115200 [bps]
F21 <sup>*2</sup>	RS485 stop bit length	1, 2 [bit]			1 [bit]
F22 <sup>*2</sup>	RS485 parity bit	None (--), Even (En), Odd (od)			Even (En)
F23 <sup>*2</sup>	With or without RS485 terminal resistor	With, without			Without
F00	Reset of all of accumulated values	To be cleared, not to be cleared	Not to be cleared		
FFF <sup>*3</sup>	Reset to standard factory delivery settings	To be reset, not to be reset	Not to be reset		

\*1 This is an output item for contact output 2 and is selectable only for B and D.

\*2 This is an item related to RS485 communication and is selectable only for R.

\*3 After resetting, "F9: Output pulse unit" will be set to 1000 [L], and "F14: Fluid selection" will be set to Air.

\*4  $Q_{\min}$  is the following value depending on the nominal diameter.

25A	32A	40A	50A	65A	80A
0.6	1.1	1.3	2.5	4.0	5.0

[m<sup>3</sup>/h]

## 2-2 Procedures to change settings

Change in settings should be made by button operation by referring to the display switching flow.



SW3 should be operated by using the hexagonal wrench included as the accessory, etc. Pressing it with any pointed sharp blade will become the cause of damage.

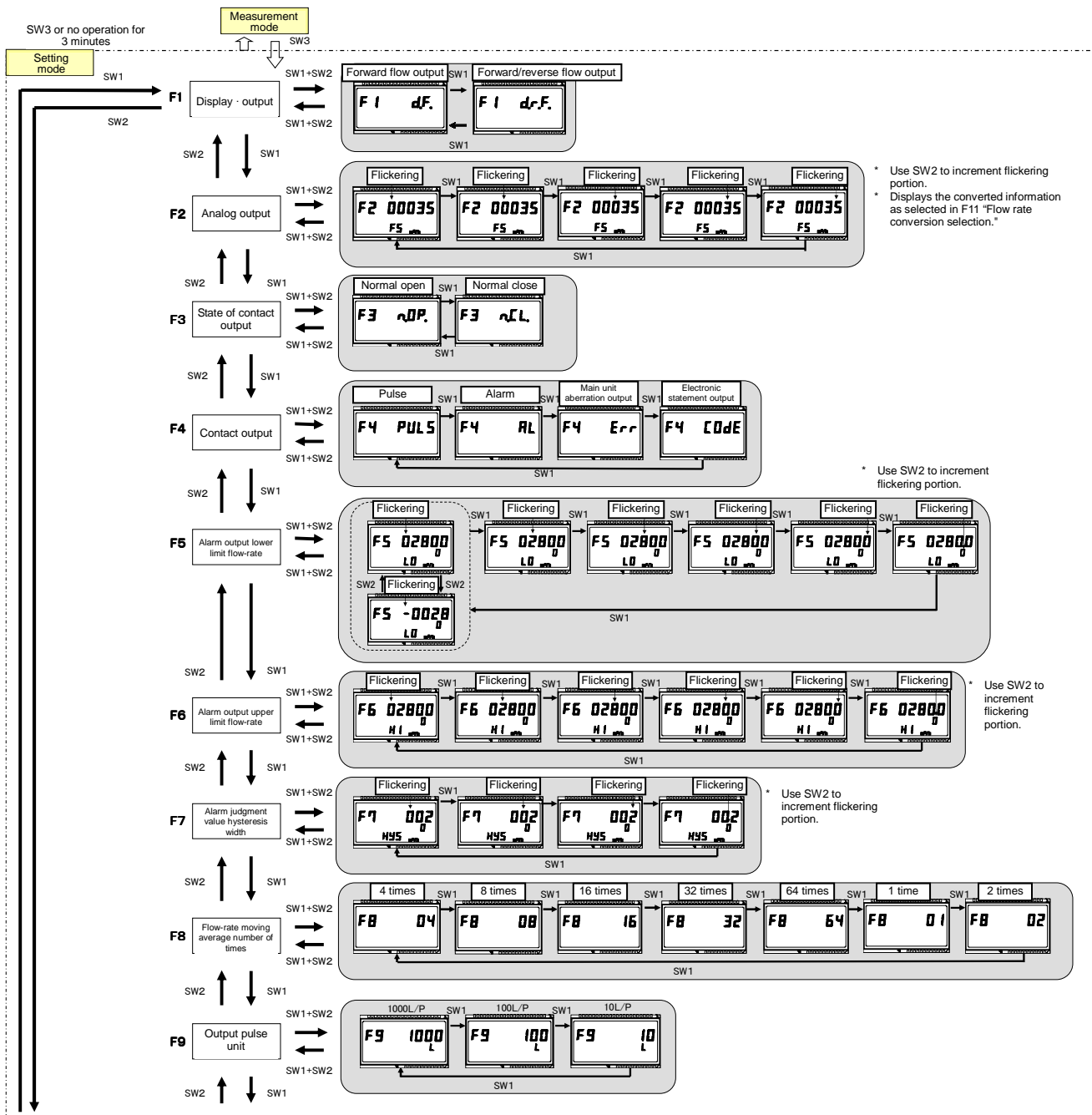

Fig. 2-1 Flow of display changeover in settings mode (B, D) (1/2)

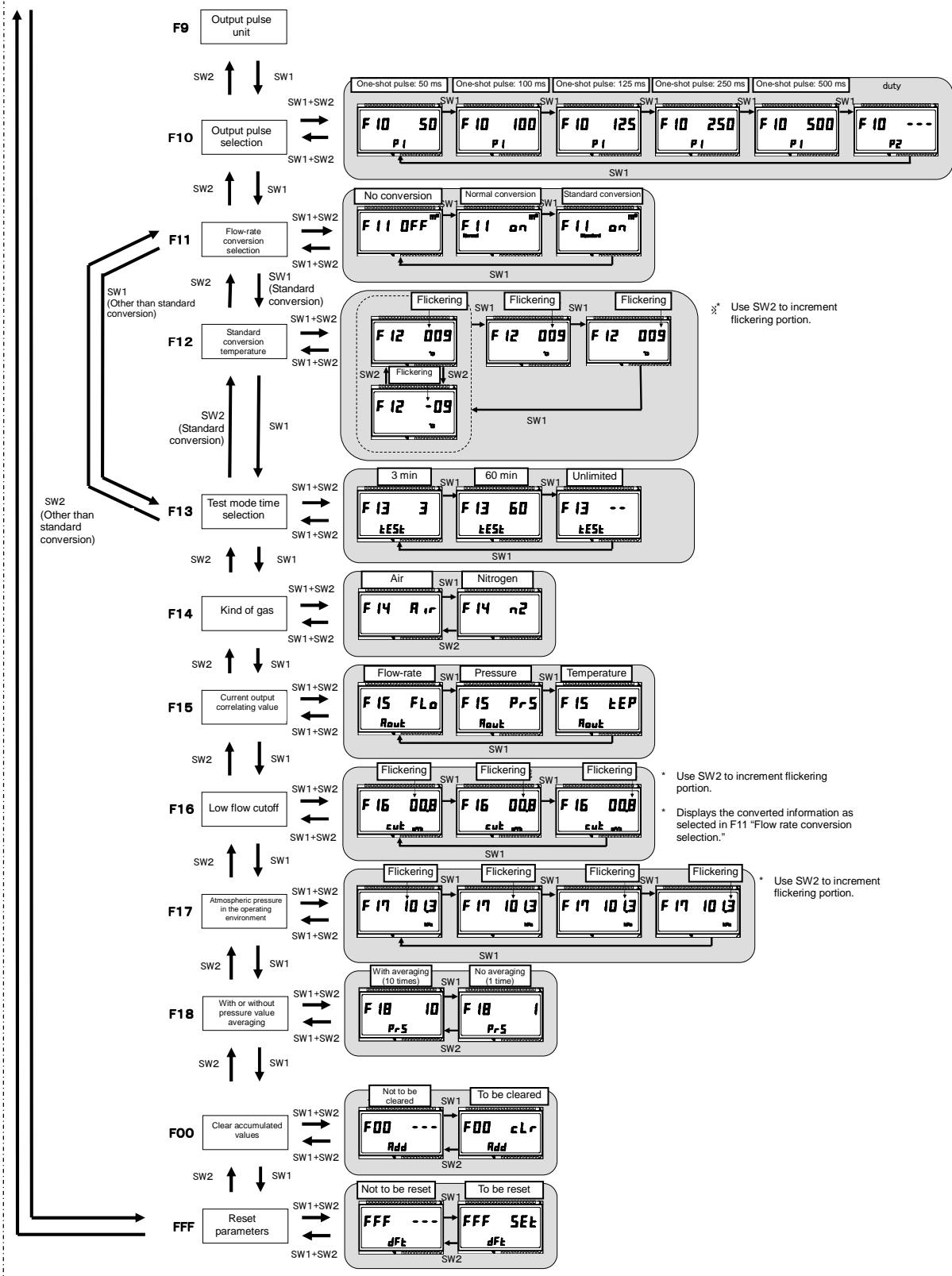

Fig. 2-2 Flow of display changeover in settings mode (B, D) (2/2)

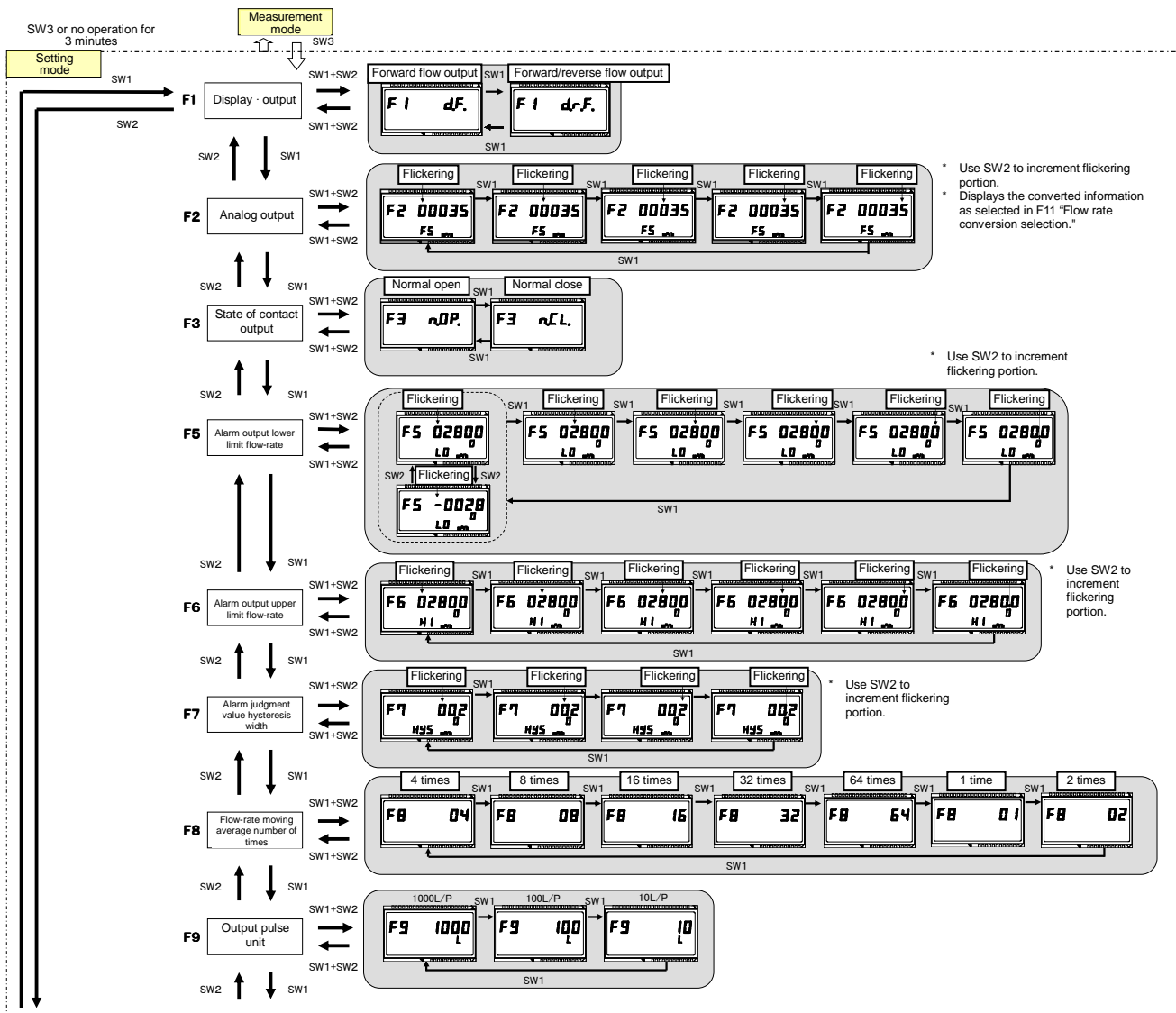

Fig. 2-3 Flow of display changeover in settings mode (R) (1/3)

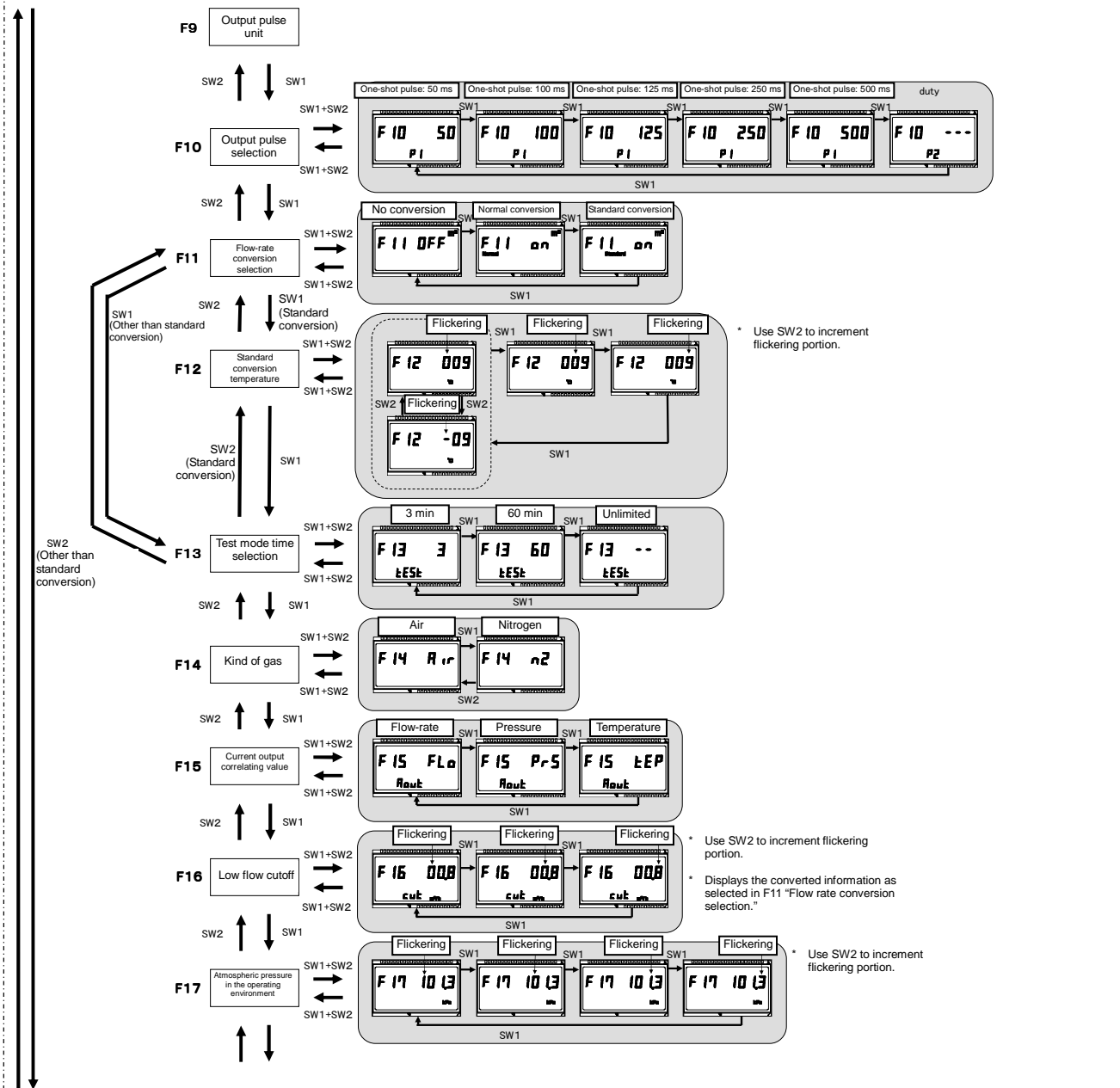

Fig. 2-4 Flow of display changeover in settings mode (R) (2/3)

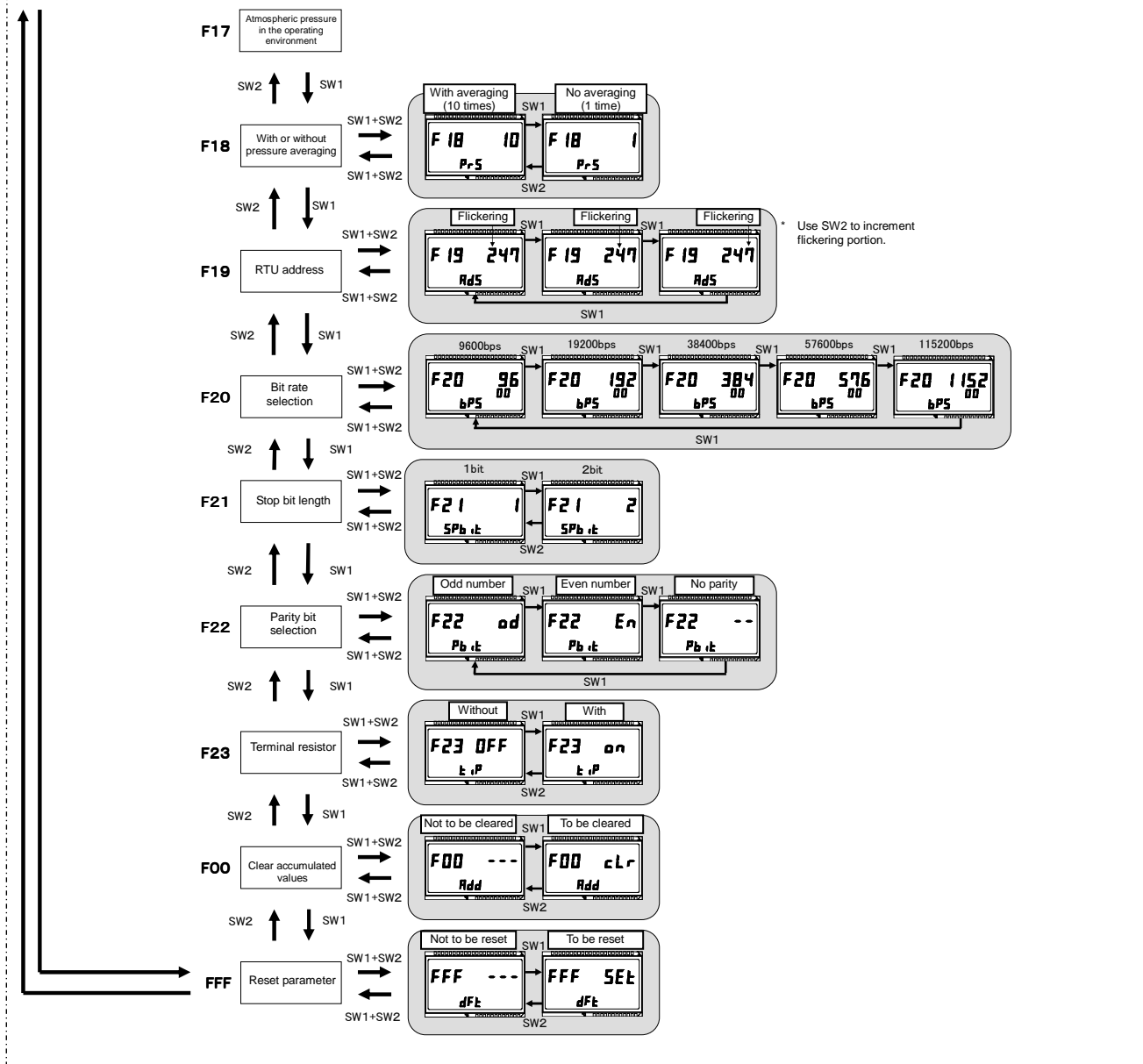

Fig. 2-5 Flow of display changeover in settings mode (R) (3/3)

[Making settings via RS485 communication]

The settings above can be made via RS485 communication. (Except “F23: With or without RS485 terminator resistor”)

Make settings via RS485 communication under conditions where button operations may be difficult, such as when the flow meter is used at heights. For details on communication, refer to the communication specifications, which can be downloaded from our website.

## 2-3 Details of setting items

### [F1] Display•Output (selectable for B, D, R)

In the Display•output, select “Forward flow (d. F.)” measurement or “Forward/reverse flow (d.r. F)” measurement.

- When the “Forward flow” measurement is selected  
The “Forward accumulated flow volume (Total)” or the “Accumulated flow volume (Trip)” can be indicated on the main display.  
Analog output at the time of zero flow-rate is 4 mA. (when [F15]: Instantaneous flow-rate is selected).
- When the “Forward/reverse flow” is selected  
The “Forward accumulated flow volume (Total)” or “Reverse accumulated flow volume (Total)” can be indicated on the main display.  
Analog output at the time of zero flow-rate is 12 mA. (when [F15]: Instantaneous flow-rate is selected).

### [F2] Analog output FS flow-rate (selectable for B, D, R)

This function can set a full scale flow-rate value for current output (5 digits).

This setting takes effect when [F15] Current output correlation value is set to "Instantaneous flow-rate."

The FS flow-rate corresponds according to the setting of [F11] Flow-value conversion selection.

### [F3] State of contact output (selectable for B, D, R)

Select "Normal open (n. OP)" or "Normal close (n. CL)."

Set this to "Normal open" in case of using a battery-powered signal receiving device.

### [F4] Contact output (selectable for B, D)

Select the output signal of open drain output 2 from “pulse output (reverse flow) (PULS),” “main unit aberration output (Err),” “upper/lower limit flow-rate alarm output (AL),” and “electronic statement output (COdE).”

“Main unit aberration output (Err)” outputs signals when one of the following occurs: ultrasonic measurement aberration, pressure measurement aberration, temperature measurement aberration, battery voltage reduction (B only), communication line aberration, and elapse of 11 years.

### [F5] Lower limit alarm flow-rate (selectable for B, D, R)\*

Use this to set the lower limit alarm flow-rate (5 digits) as the lower limit flow-rate value for the upper/lower limit flow-rate alarm.

- \* For the built-in battery specification (B) and external power supply specification (D), this is the judgment value for flow-rate lower limit alarm output of open drain output 2.  
For the RS485 output specification (R), this is the judgment value for "Error information and Flow-rate upper/lower limit aberrations Y/N" of flow meter information of the RS485 communication function.

### [F6] Upper limit alarm flow-rate (selectable for B, D, R)\*

Use this to set the upper limit alarm flow-rate (5 digits) as the upper limit flow-rate value for the upper/lower limit flow-rate alarm.

- \* For the built-in battery specification (B) and external power supply specification (D), this is the judgment value for flow-rate upper limit alarm output of open drain output 2.  
For the RS485 output specification (R), this is the judgment value for "Error information and Flow-rate upper/lower limit aberrations Y/N" of flow meter information of the RS485 communication function.





[F10] Pulse output method (selectable for B, D, R)

Select from one of the five one-shot modes (ON time "50ms," "100ms," "125ms," "250ms," or "500ms") or Duty mode.

Selecting one of the one-shot modes is recommended in case the signal receiving instrument you are using is battery-powered.

Make sure to check the specifications of the signal receiving instrument and set the appropriate ON time from Table 2-2.

[F11] Flow-rate conversion selection (selectable for B, D, R)

Select "actual flow-rate (OFF)", "normal conversion flow-rate (Normal)", or "standard conversion flow-rate (Standard)" for flow value conversion. If you select "normal conversion flow-rate (Normal)," the "Normal" lamp above the partition line will flash. If you select "standard conversion flow-rate (Standard)," the "Standard" lamp will flash. If you select "N," both lamps will turn off.

The accumulated flow volume display, instantaneous flow-rate display, and output signal will all correspond to the selection of whether to convert the flow-rate or not.

See below for the definition of flow-rate conversion and the conversion equation.

$$Q_2 [\text{Nm}^3/\text{h}] = \frac{273.15}{(273.15+t)} \times \frac{P_1 + \text{Atmospheric pressure in the operating environment} [\text{kPa}] [\text{F17}]}{101.33} \times q_1$$

$Q_2$ : Normal conversion flow-rate [ $\text{Nm}^3/\text{h}$ ]

t: Measured temperature [ $^{\circ}\text{C}$ ]

$P_1$ : Measured pressure [kPa]

$q_1$ : Actual flow-rate [ $\text{m}^3/\text{h}$ ]

$$Q_2 [\text{Sm}^3/\text{h}] = \frac{273.15+T}{(273.15+t)} \times \frac{P_1 + \text{Atmospheric pressure in the operating environment} [\text{kPa}] [\text{F17}]}{101.33} \times q_1$$

$Q_2$ : Standard flow-rate [ $\text{Sm}^3/\text{h}$ ]

T: Standard conversion temperature [ $^{\circ}\text{C}$ ] [F12]

t: Measured temperature [ $^{\circ}\text{C}$ ]

$P_1$ : Measured pressure [kPa]

$q_1$ : Actual flow-rate [ $\text{m}^3/\text{h}$ ]

[F12] Standard conversion temperature (selectable for B, D, R)

This is used to set the temperature [ $^{\circ}\text{C}$ ] to use as the basis for standard conversion.

The temperature can be set within a range between  $-10^{\circ}\text{C}$  and  $+60^{\circ}\text{C}$  in  $1^{\circ}\text{C}$  increments.

This setting is not available if an option other than standard conversion is selected in [F11].

[F13] Test mode time selection (selectable for B, D, R)

Test mode times available for selection are "3 min. (3)," "60 min. (60)," and "Unlimited (--)."

[F14] Fluid selection (selectable for B, D, R)

Select either "Air (Air)" or "Nitrogen (N2)."

Even if you specified a flow meter for air in your initial order (Model: TRX [nominal diameter] [power supply specification]-C/5P), you can change this setting so that it can be used for nitrogen.

[F15] Current output correlation value (selectable for B, D, R)  
Select "Instantaneous flow-rate (FLo)", "Pressure (PrS)", or "Temperature (tEP)" for the functional assignment of the current output.  
When instantaneous flow-rate is selected, the instantaneous flow-rate correlation value that you have selected in [F11] Flow-value conversion selection will be used.

[F16] Low flow cutoff flow-rate (selectable for B, D, R)  
This is for setting the low flow cutoff flow-rate (Qcut) where the instantaneous flow-rate is  $0\text{m}^3/\text{h}$ .  
The settable range is defined as  $0 \leq Q_{\text{cut}} \leq Q_{\text{min}}$ .  
The set flow-rate will be the flow-rate you selected in [F11] Flow-value conversion selection.

[F17] Atmospheric pressure of the working environment (selectable for B, D, R)  
This is used to set the atmospheric pressure value (4 digits) [kPa] of the working environment in absolute pressure.  
The standard factory setting has been set to 101.3 [kPa]. Leave this setting unchanged unless you are operating the meter at higher elevations, etc.

[F18] With or without pressure value averaging (selectable for B, D, R)  
Set with or without pressure value averaging to either "With averaging (10)" or "No averaging (1)." If "With averaging" is selected, the moving average value of the 10 most recently measured pressures is used for display and output.

**[F19] thru [F23] are settings relating to RS485 communication. Make sure these settings match those on your master equipment. The settings cannot be made for the external power supply specification (D) and the built-in battery specification (B).**

[F19] RTU address (selectable for R)  
Select a value between 001 to 247 for RTU address of this meter.

[F20] RS485 communication bit rate (selectable for R)  
Select "9600 bps (9600)", "19200 bps (19200)", "38400 bps (38400)", "57600 bps (57600)", or "115200 bps (115200)" for the communication bit rate.

[F21] RS485 communication stop bit length (selectable for R)  
Select either "1 bit (1)" or "2 bits (2)" for the stop bit length.

[F22] RS485 communication parity bit (selectable for R)  
Select either "None (--)", "Even number (En)", or "Odd number (Od)" for the parity bit.

[F23] With or without RS485 terminal resistor (selectable for R)  
Select either "Yes (on)" or "No (OFF)" for the terminator resistor.  
The meter's communication circuit comes with a built-in 100 ohm terminal resistor, so you do not need to use an external resistor.  
In configurations connecting multiple meters to a signal receiving device (master device), set the terminator ON on the meter that is physically the farthest distance away.

[F00] Reset of all of accumulated values (selectable for B, D, R)

By selecting "Clear (cLr)", the values for Accumulated flow volume (Forward flow), Accumulated flow volume (Reverse flow), and Trip accumulated flow volume are reset to zero.

[FFF] Reset to standard factory delivery settings (selectable for B, D, R)

By selecting "Reset (SEt)", settings are reset to standard factory settings shown in Table 2-1. However, "F9 Output pulse unit" alone will be set to 1000L/P for all nominal diameters, and "F14 Fluid selection" will be set to Air.

### 3. Installation

Reminders relating to installation and recommended piping conditions are described in paragraphs 1) thru 12) below.

**⚠** Please read this section carefully as some conditions will render the meter incapable of making correct measurements.

- 1) Match the arrow on the meter with the forward flow direction of the fluid.
- 2) Fig. 3-1 below shows the recommended lengths of straight pipe sections for the meter under different piping conditions.

Conditions	Upstream	Downstream
90° elbow Full-bore valve fully opened		
Merging		
Enlarge pipe		
Narrowing pipe		

Fig. 3-1 Recommended straight pipe lengths 1 (D: gauge)

- 3) Because ultrasonic noise can be produced inside the pipes if the meter is installed near a pressure reducing valve or flow control valve, make sure to comply with the "required straight pipe length L" shown in Fig. 3-2 below.

**Be particularly careful of the fact that there are major constraints to installing the flow meter downstream of a pressure reducing valve, etc. (The meter may not be able to take measurements if conditions are not met).**

$\text{Required straight pipe length L (mm)} = 10D + \frac{\text{differential pressure (kPa)} \times D \times \frac{\text{Maximum working flow-rate (m/s)}}{20 \text{ (m/s)}} \times (0.8)^{\text{number of elbows}}}{1}$
---

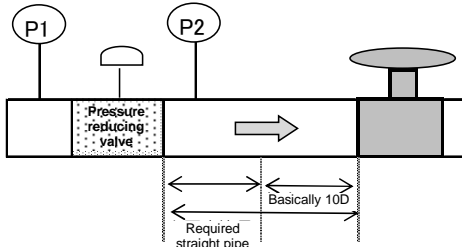
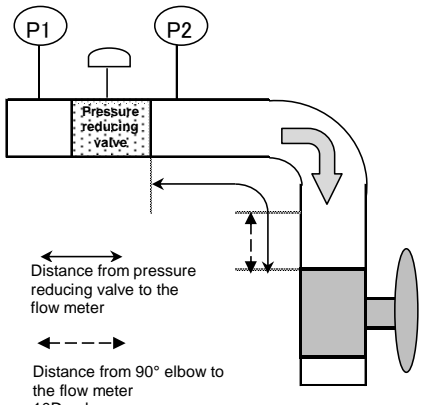
To install the meter downstream of a pressure reducing valve	
Without elbow	With elbow (Elbows attenuate ultrasonic noises. If multiple elbows are used, the required length will be shorter.)
 <p>(Calculation example)            Example 1: DN50A, Flow-rate 10m/s, No elbow used            Where P1 = 25kPa and P2 = 5kPa  <math>500 + (25 - 5) \times 50 \times 10 / 20 = 1000\text{mm (20D)}</math></p> <p>Example 2: DN50A, Flow-rate 10m/s, No elbow used            Where P1 = 160kPa and P2 = 10kPa  <math>500 + (160 - 10) \times 50 \times 10 / 20 = 4250\text{mm (85D)}</math></p>	 <p>(Calculation example)            Example 1: DN50A, Flow-rate 10m/s, One elbow used            Where P1 = 160kPa and P2 = 10kPa  <math>500 + (160 - 10) \times 50 \times 10 / 20 \times 0.8 = 3500\text{mm (70D)}</math></p>

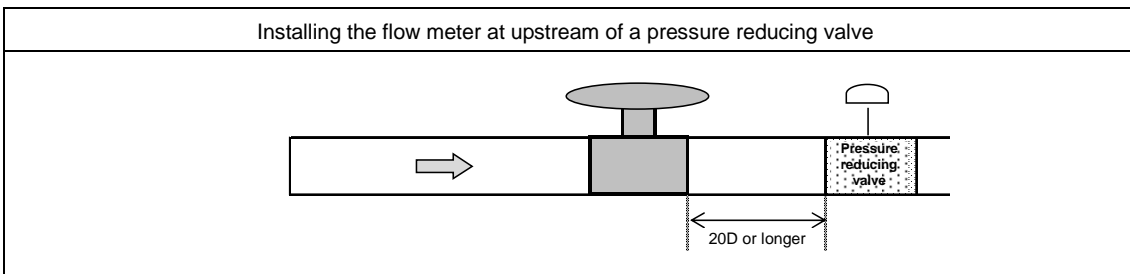

Fig. 3-2 Recommended straight pipe lengths 2 (D: gauge)  
 (Installing the flow meter near a pressure reducing valve or a flow control valve)

- 4) When installing a wafer type flow meter, make sure to align the central axis of the meter with that of the piping. In order to make the deviation of the central axes of the flow meter and piping, use the centering collars provided as an accessory. Insert the centering collars into the holes of the flange packings and flanges as shown in Fig. 3-3. The central axis of the meter can be aligned with that of the piping by making the flow meter contact the collars. In situations where it is difficult to install the collars on both the up and downstream sides of the meter due to piping misalignment or other reason, install them on only the upstream side.

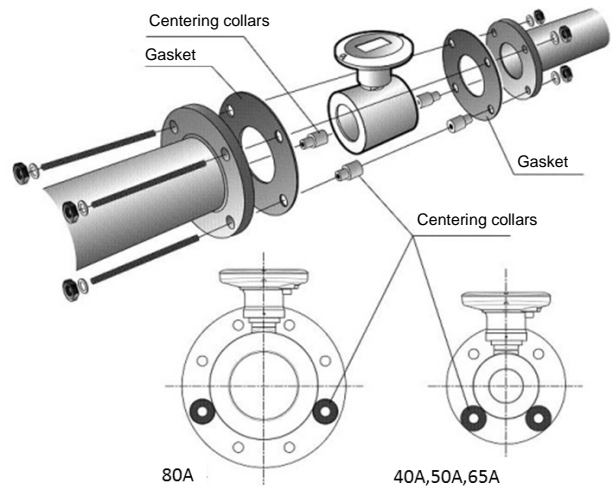
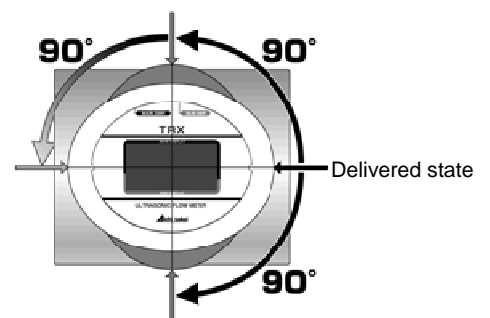

Fig. 3-3 Installation example of the centering collars

- 5) This flow meter can be installed indoors or outdoors, and on either horizontal or vertical piping. Make sure that it is installed on a straight section of the pipe. The flow meter is recommended to be installed on vertical piping if the air contains significant amounts of mist, dust, or other material. Also, when installing the meter horizontally on a similar pipe, make sure to install it so that the display area faces up. This flow meter is not of a perfect waterproof structure (IP64). Do not install it at a place that may be submerged in water. The installation of a sunshade is recommended if the flow meter is exposed to direct sunlight. If it will be installed in an area where it can be exposed to falling rain, make sure to install the meter so that its display area does not face down.
- 6) Fasten wafer type flow meters using M16 stud bolts, etc., on both sides. (Refer to Fig. 3-3.) When tightening the bolts and nuts, tighten evenly to prevent partial tightening.
- 7) With wafer type flow meters, make sure that the flange packings do not protrude into the interior of the pipes.
- 8) With screw connection type flow meters, screw on the tapered threads for piping using the torques shown below.

TRX25A (R1): 36 to 38Nm TRX32A (R1-1/4): 47 to 49Nm
--

- 9) The display portion can be rotated to change its orientation. Do this before installing the meter is recommended. To change the display's orientation, loosen the set screw at the neck portion of the display using an M4 hex wrench and then rotate the display portion. Once it is in the desired orientation, always make sure to tighten the set screw to fix the display portion in place. When rotating the display section, do not apply a force in a direction other than the rotating direction.



The display portion can be rotated clockwise by 90 degrees and counter clockwise by 180 degrees from the orientation it was in when it left the factory.
--

- 10) When making piping connections, make sure that foreign material such as weld chips, debris, and sealant do not make their way into the pipes. In the case of new piping, install the product after sufficient cleaning of the pipe(s).
- 11) Do not install the flow meter in sections where it will be subjected to significant compression forces, tensile loads, and other loads after it is installed.
- 12) When making piping connections, make sure not to touch the interior of the meter, particularly its ultrasonic sensors (See p.1). Also make sure not to drop the meter, hit it against other objects, or otherwise subject it to excessive shocks.
  - ⊘ Do not hold the display section of this flow meter.



#### 4. Wiring connection

 Be sure to perform the wiring work in a state that power supply from the external power supply is interrupted.

The input/output circuit diagram is shown in Fig. 4-1 to Fig. 4-3.

Make wiring connections using the exclusive external connection cable.

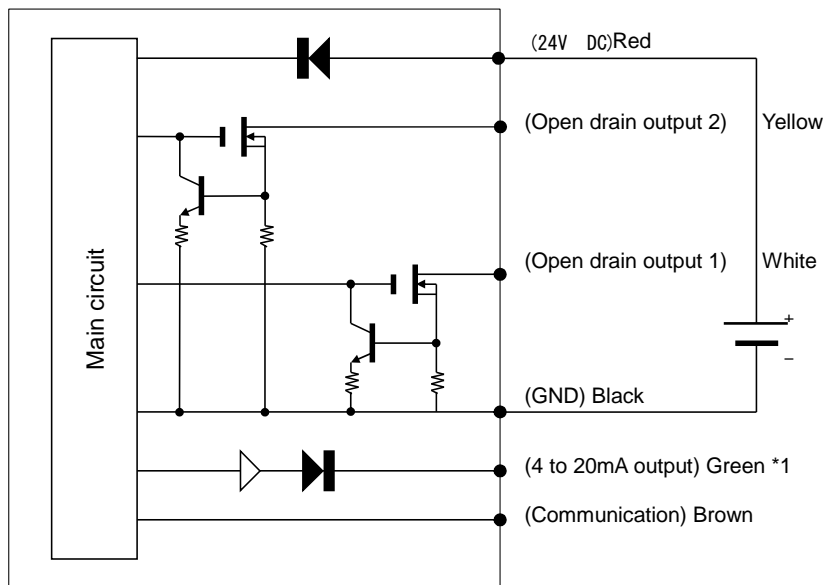

\*1 Load resistance 400 ohms or smaller

Fig. 4-1 Input/output circuit diagram (external power supply specification: D)

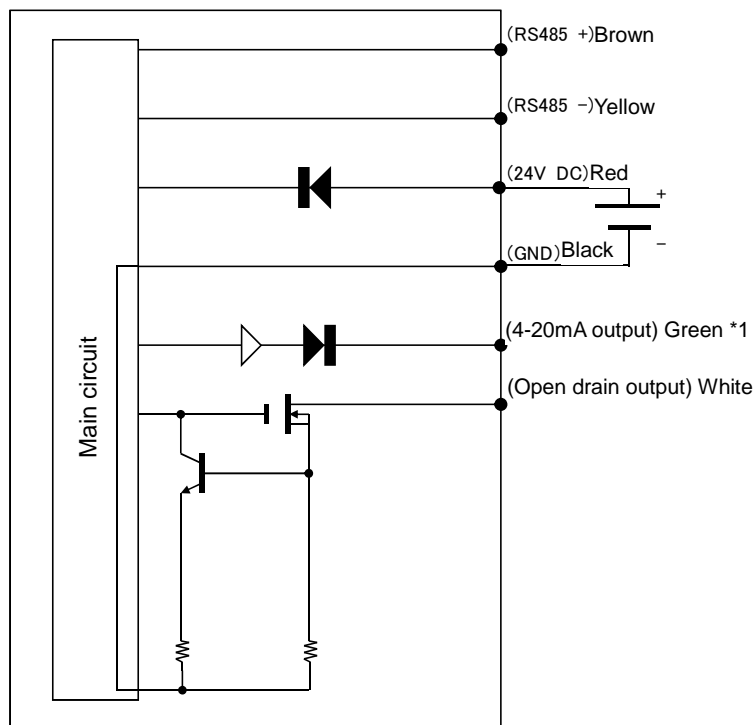

\*1 Load resistance 400 ohms or smaller

Fig. 4-2 Input/output circuit diagram (RS485 output specification: R)

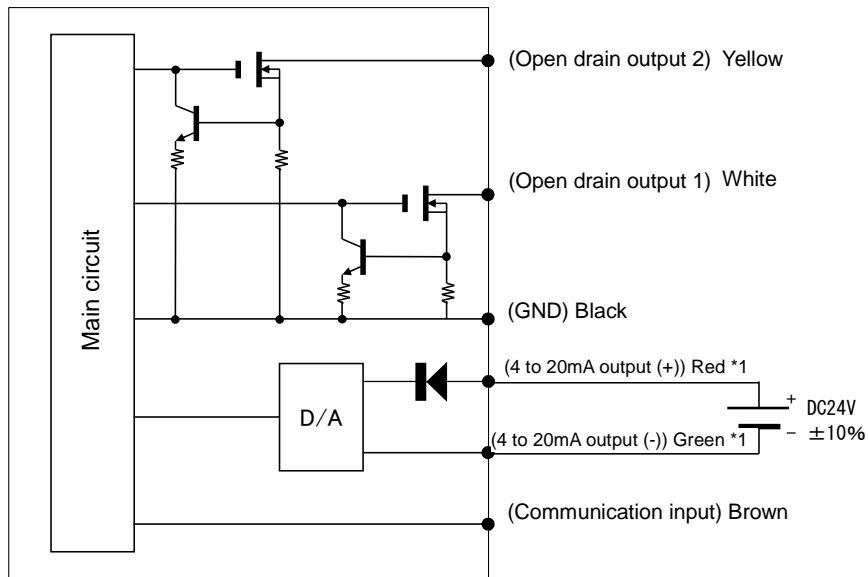

\*1 Analog output requires an additional power supply (24 VDC).  
Load resistance 400 ohms or smaller

Fig. 4-3 Input/output circuit diagram (built-in battery specification: B)

[Reminders regarding power supply and ground]

- **The meter's enclosure (metal components) and GND are electrically shared.**  
Ground the power supply to negative. (Do not ground it to positive)  
Or, select an isolated power supply.
- If it is installed near the electric noise source, ground the braided shield of the external connection cable.
- Select a power supply with more than sufficient power supplying capacity.  
1.5W or greater is recommended.

[Reminders regarding connection with indicators (RS485 output specification: R)]

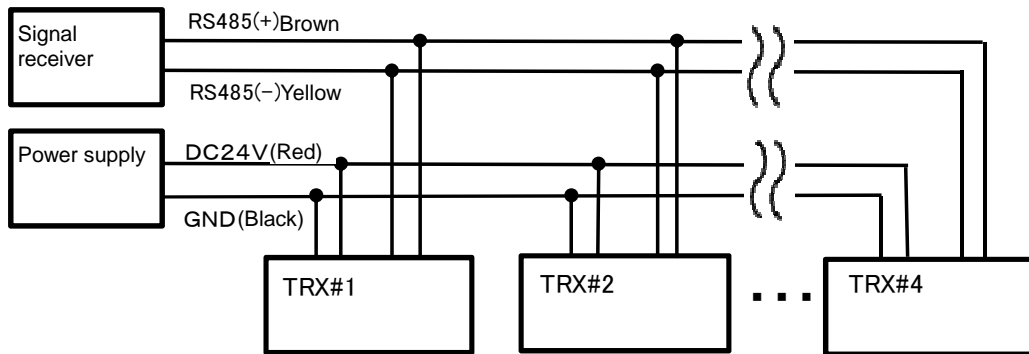

Fig. 4-4 Signal receiver and connections (RS485 output specification: R)

- Do not ground the brown and yellow communication lines.
- If multiple meters are to be connected as shown in Fig. 4-4, choose a power supply with more than sufficient power supply capacity. A rough guideline would be 1.5W multiplied by the number of units connected.
- If multiple meters are to be connected, designate unique RTU addresses (001 to 247) to avoid address conflicts.
- Activate the 100 ohm terminator resistor between communication lines only on the meter that is physically the farthest away from the signal receiver. In Fig. 4-4, (TRX#4) would be the applicable one.
- Take into account any corruption in the communication waveform when determining the number of meters to connect and the bit rate.  
\*Corruption which results from cable line resistance and line capacity.
- Connecting the communication line in +/- reverse will not destroy the communication circuit. But you will not be able to establish communication. Please connect it correctly.
- When connecting an external connection cable, use an equivalent of or one with a higher capacity than a six-core cable UL style 20276-5B AWGx6C (2).

[Reminders regarding connection with indicators (external power supply specification: D, built-in battery specification: B)]

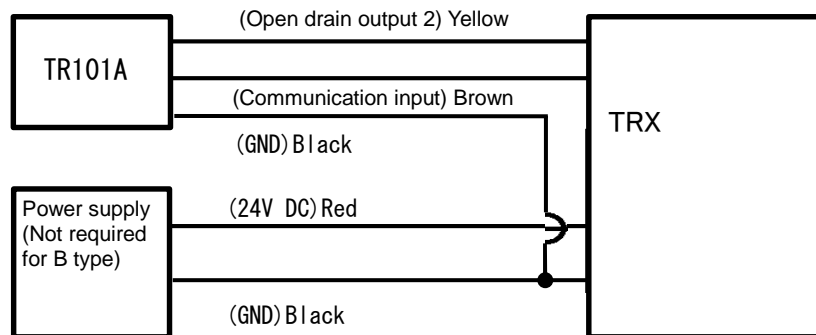

Fig. 4-5 Signal receiver and connections (external power supply specification: D, built-in battery specification: B) Signal receiver

- Make a one-to-one connection between TRX and an indicator. (Multiple units cannot be connected.)
- If you perform continuous communications with the built-in battery specification (B), the battery life may become shorter. Perform communication at intervals of 10 minutes or longer.

[Reminders regarding 4-20mA outputs (external power supply specification: D, 2: R)]

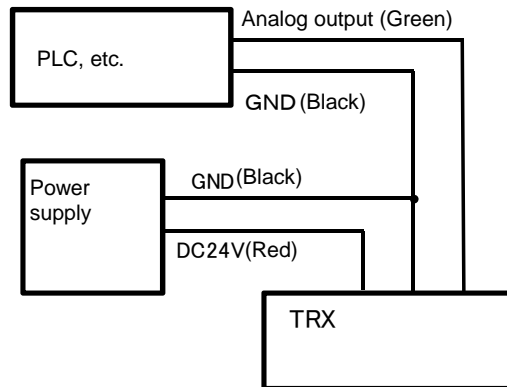

Fig. 4-6 Connection with PLC (external power supply specification: D, RS485 output specification: R)

- Do not ground the 4-20mA output terminal (green). You will not be able to correctly measure output current.
- Use a load resistance of no greater than 400 ohms. Connecting a load greater than 400 ohms will cause a drop in voltage and it will not be able to output the specified current.

[Reminders regarding 4-20mA outputs (built-in battery specification)]

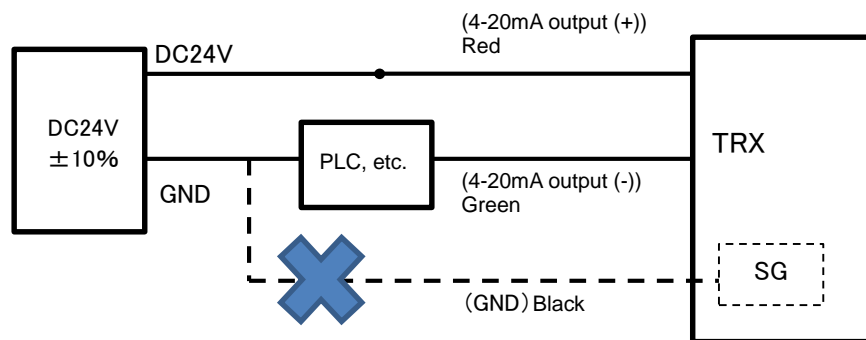

Fig. 4-7 Connection with PLC (built-in battery specification: B)

- To use analog output, an additional external power supply (24 VDC±10%) is required.
- The meter's enclosure (metal components) and GND are electrically shared. When continuity occurs between the enclosure (metal pipe) and the ground of an external power supply, current will not be output correctly. Insulate the enclosure (metal pipe) and the ground of the power supply.
- Use a load resistance of no greater than 400 ohms. Connecting a load greater than 400 ohms will cause a drop in voltage and it will not be able to output the specified current.

[Reminders on open drain outputs]

(Selecting the type of pulse output)

This meter gives you a choice of two types of outputs: duty output and one-shot output. The meter is set to duty output when it leaves the factory.

Under duty output, the ON:OFF times are 1:1. Under one-shot output you can set the ON times shorter between 50 to 500ms (Fig. 4-8). Therefore, if you are using a battery-powered pulse receiving signal receiver, using a one-shot pulse output is recommended to improve battery life.

Please keep the following points in mind with regard to selecting one-shot.

- Check the waveform corruption caused by the cable (line capacity, line resistance) and the minimum input signal width of the signal receiver to choose the appropriate ON time.
- ON/OFF will reverse if you choose "Normal close."

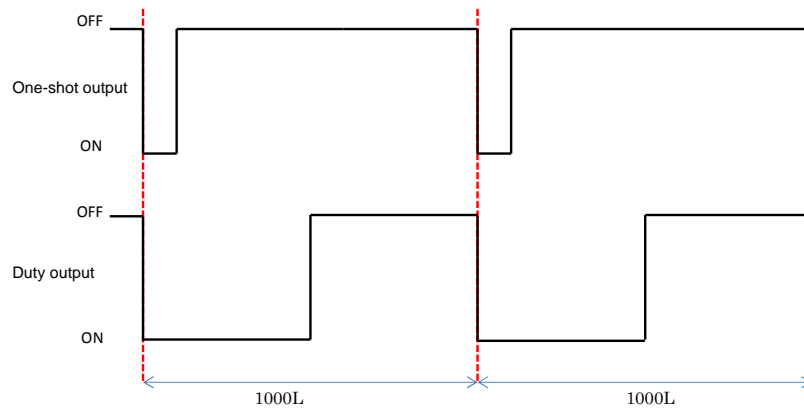

Fig. 4-8 Characteristics of one-shot output and duty output  
(Example with pulse constant at 1000L/P, and Normal open)

(Example of pull-up resistance calculation)

Check the pulse receiving signal receiver's specifications (power supply voltage Vdd [V] and ON current Ion [mA]) and select the pull-up resistance constant using equation (1).

$$R[\Omega] = [(V_{dd} - 0.2) / (I_{on} \times 10^{-3})] - 24.7 \dots \text{(Equation 1)}$$

\*Do not allow the current Ion to exceed the maximum load of 24 VDC and 50 mA.

Example where Vdd=24V and Ion=10mA

$$R[\Omega] = [(24 - 0.2) / (10 \times 10^{-3})] - 24.7 = 2355[\Omega] \cong 2.2[k\Omega]$$

## 5. Operation



Do not open or close valves abruptly. Make sure to open and close them gradually.  
Opening or closing of the valve all at once may cause a failure of the flow meter if a pressure difference is occurring between the upstream side and downstream side of the valve.

When you are running the meter for the first time, check that the pilot lamp is flickering.  
(A flickering pilot lamp indicates that the fluid is flowing.)

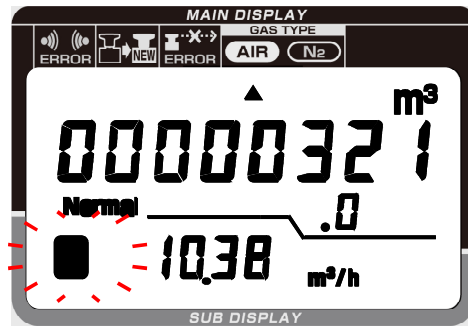

Fig. 5-1 display start of operation.

## 6. Display and output under aberrant states

### 1) Aberration in flow measurement

[State] Unable to receive ultrasonic signals.

[Display] The triangle in the upper left of the LCD **flickers**.

The instantaneous flow-rate value in the sub-display shows "0.00."

As for the accumulated flow volume value display, the accumulation process is stopped and the display shows the value immediately prior to the aberration.

[Output] Analog output: 4mA

Open drain output: Stopped

[Cause] There is a possibility that foreign materials (liquids such as oils) has become stuck to or is being retained in the measurement pipe, and is obstructing the propagation of ultrasonic.

If the alarm persists even after removing the foreign materials, please contact your nearest Aichi Tokei Denki branch or sales office.

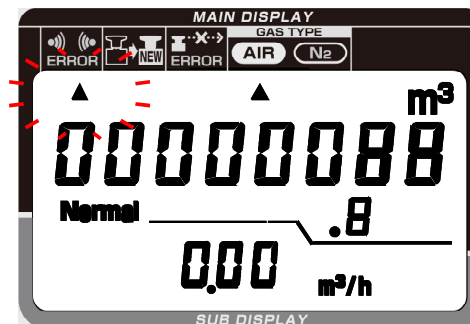

Fig. 6-1 Flow measurement aberration display

(Note) Actions when the meter is first run

Once the flow meter is installed and measurements begin, the meter may show a "flow measurement aberration display" due to the sudden change in pressure from the atmospheric pressure. This will stop once the pressure of the fluid stabilizes under working conditions. (This will return to normal.)

2) Aberrant pressure value

[State] This state indicates that the pressure value has exceeded the measurement limits.

[Display] The pressure display in the sub-display shows the aberrant value and flickers.

The instantaneous flow-rate value in the sub-display shows "0.00" and flickers. (The display of temperature value flashes)

As for the accumulated flow volume value in the main display, the accumulation process stops and the display shows the value immediately prior to the aberration.

[Output] Analog output: 4mA

Open drain output: Stopped

[Cause] The pressure used may have exceeded the specified range.

Other potential causes include pressure sensor failure, please contact your nearest Aichi Tokei Denki branch or sales office.

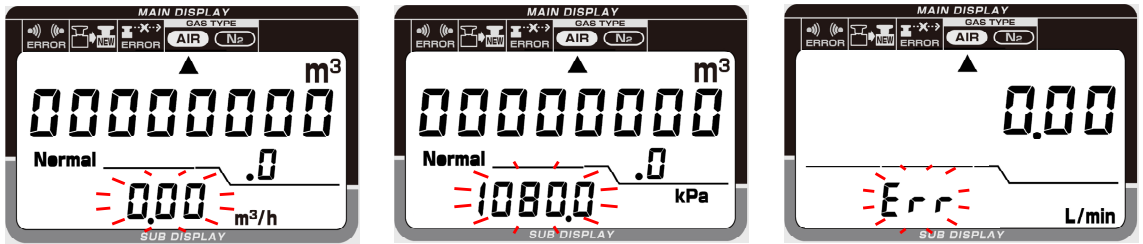

At the display of accumulated flow volume (forward flow), trip accumulated flow volume, and accumulated flow volume (reverse flow) displays

At the display of the instantaneous flow-rate display (L/min)

Fig. 6-2 Pressure aberration displays

3) Aberrant temperature value

[State] This state indicates that the temperature value has exceeded the measurement limits.

[Display] The temperature display in the sub-display shows the aberrant value and flickers.

The instantaneous flow-rate value in the sub-display shows "0.00" and flickers. (The display of pressure value flashes)

As for the accumulated flow volume value in the main display, the accumulation process stops and the display shows the value immediately prior to the aberration.

[Output] Analog output: 4mA

Open drain output: Stopped

[Cause] The aberrant temperature alarm may be triggered if setting of Fluid selection [F14] does not match the fluid being measured. If the setting is correct and you are still getting an aberrant temperature alarm, please contact your nearest Aichi Tokei Denki branch or sales office.

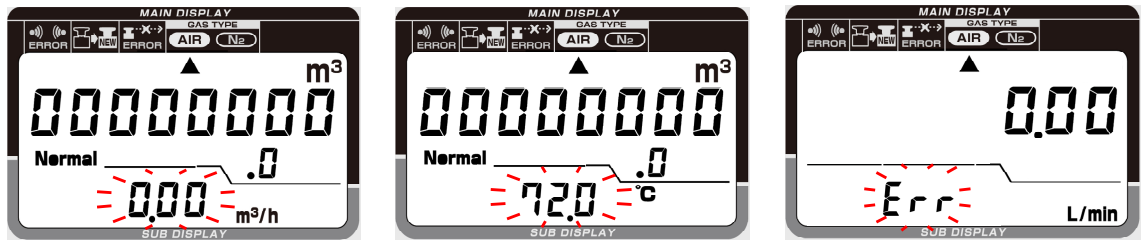

At the display of accumulated flow volume (forward flow), trip accumulated flow volume, and accumulated flow volume (reverse flow) displays

At the display of the instantaneous flow-rate display (L/min)

Fig. 6-3 Temperature aberration displays

4) Memory aberration

[State] There is an aberration in the data in the non-volatile memory.

[1] User's area: An aberration is found in the data for settings that were changed by button operations, or in the accumulated value data upon powering the meter on.

[2] System area: An aberration is found in the data for the system (setting by users is not available).

[Display] [1] User's area: The triangle that indicates the Kind of Gas (air or nitrogen) flickers.

[2] System area: The display shows "E-2."

[Output] [1] User's area: Analog output: Normal operations  
Open drain output: Normal operations

[2] System area: Analog output: 4mA  
Open drain output: Stopped

[Cause] [1] In the case of a memory aberration in the user's area

- Check to see whether the set data is within the settable range. (Refer to Table 2-1.)
- If any aberrations are found with the set data, you can reset them using "[FFF] Reset to standard factory delivery settings." (\*)
- If any aberrations are found with the accumulated value data, perform "[F00] Reset of all of accumulated values" and power the meter back on. (\*)

\*Please note that this resets your settings data or accumulated value.

[2] In the case of a memory aberration in the system area

Please contact your nearest Aichi Tokei Denki branch or sales office.

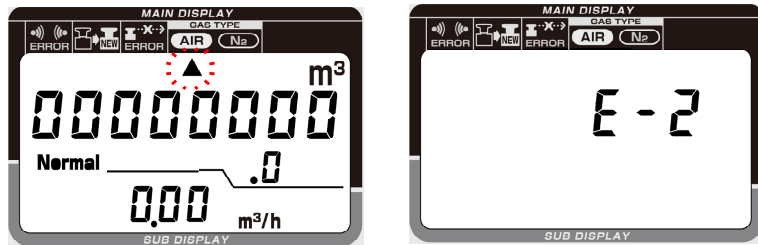

[1] User's area

[2] System area

Fig. 6-4 Memory aberration display

Table 6-1 Output and communication at aberrations

	Analog output	Open drain output	Communication
Measurement aberration	4mA	Stop	Available
Pressure aberration	4mA	Stop	Available
Temperature aberration	4mA	Stop	Available
Memory aberration (User area)	Normal operations	Normal operations	Available*
Memory aberration (System area)	4mA	Stop	Not available

\* Communication is not to be available if there is an aberration in the RS485 settings.



## 7. Operation modes

This flow meter comes with 3 operation modes between which mode transition can be operated by using buttons.

(Table 7-1, Fig. 7-1)

Table 7-1 Button operations for each operation mode

Button position and operation		Measuring modes	Settings mode		Test mode
Button position	Operation		Select setting item	Select setting value	
Left rear	SW1	Switchover among accumulated flow volume (forward flow), trip accumulated flow volume, and instantaneous flow-rate [L/min]	Switchover to the next setting item	Switchover of setting contents, Moving place of flickering digit	
		Switchover among accumulated flow volume (forward flow), accumulated flow volume (reverse flow), and instantaneous flow-rates [L/min]			
Right rear	SW2	Switchover among instantaneous flow-rate [m <sup>3</sup> /h], pressure, and temperature displays	Switchover to previous setting item	Change the value of flickering digit	Switchover to measuring mode
	SW2 (Press down for 3 sec.)	Switchover to test mode			
Center rear	SW3	Switchover to settings mode	Switchover to measuring mode		
	SW1+ SW2	Clear trip accumulated flow volume	Switchover between selecting the setting item and selecting the set value		

Note 1) "SW1+SW2" denotes steps where both switches must be pressed simultaneously.

Note 2) You cannot switch over the sub-display when the main display is set to instantaneous flow-rate [L/min]

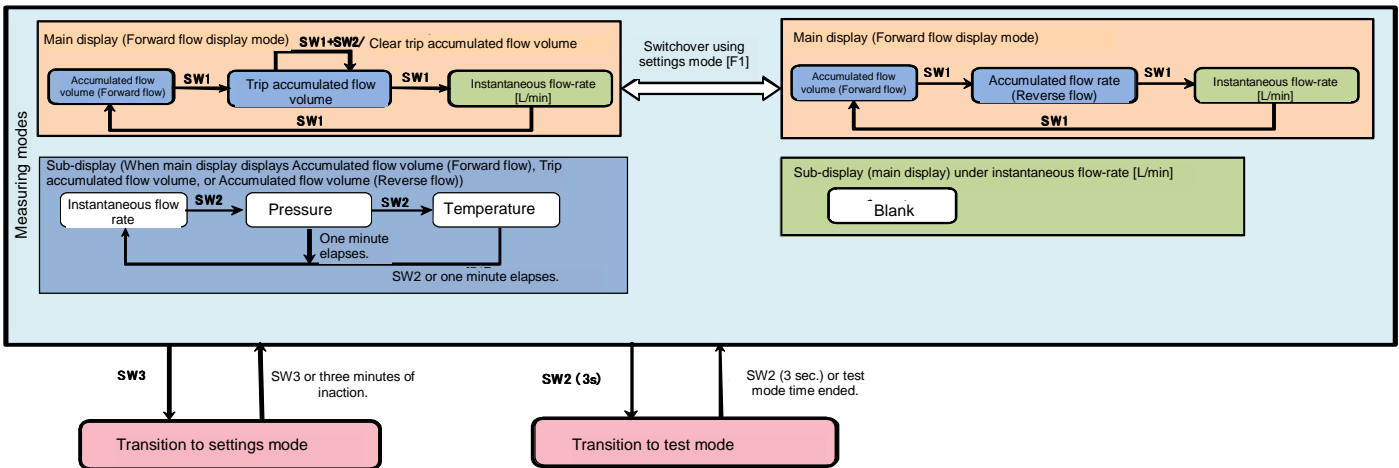

Fig. 7-1 Transitions to each operation mode

This section describes the three operation modes.

### 1) Measurement mode

[Overview]

This mode is for measuring flow-rate, pressure, and temperature. The meter will remain in this mode unless you operate any of its buttons.

[Details]

The main display (upper column) displays the accumulated flow volume, and the sub-display (lower column) shows the instantaneous flow-rate.

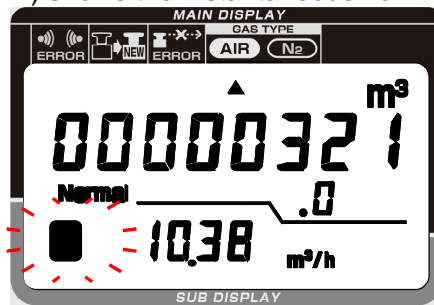

Fig. 7-2 Example of measuring mode indication

A Switchover of the main display

Where forward flow is selected in [F1: Display · output].

- Each time SW1 is pressed, the display will cycle from trip accumulated flow volume to instantaneous flow-rate [L/min] and then to accumulated flow volume (forward flow).

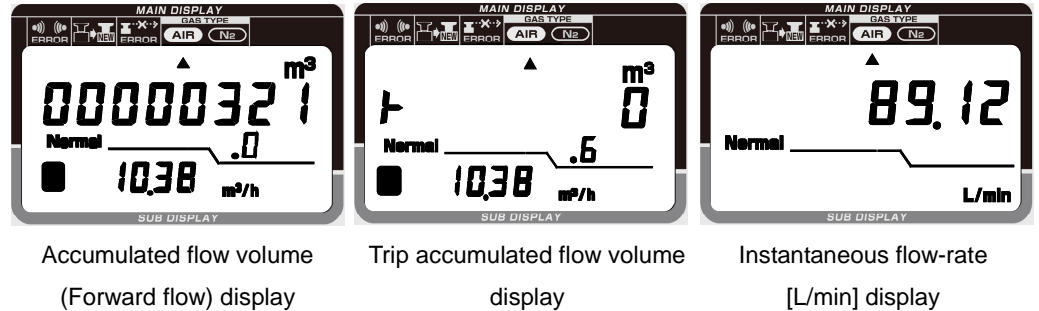

Fig. 7-3 Examples of different displays on the main display (where forward flow is selected)

- By pressing SW1 and SW2 simultaneously while trip accumulated flow volume is displayed, trip accumulated flow volume can be canceled.
- If the trip accumulated flow volume overflows beyond 9999999.9, the display will show 0000000.0 without zero suppression and continue its accumulation operations.

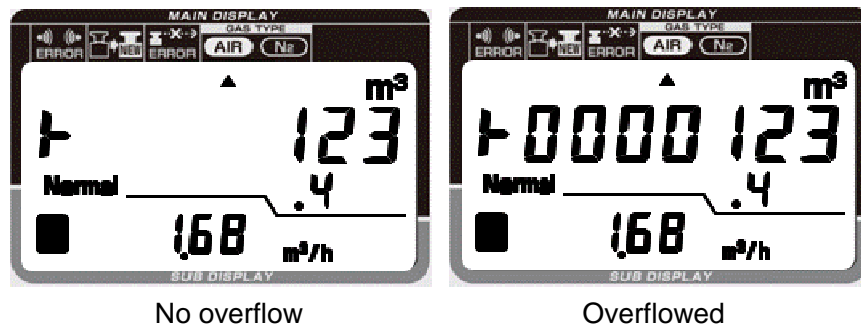

Fig. 7-4 Trip accumulated flow volume display (example)

Where forward/reverse flow is selected in [F1: Display · output]:

- Each time SW1 is pressed, the display will cycle from accumulated flow volume (Reverse flow) to instantaneous flow-rate [L/min] and then to accumulated flow volume (forward flow).

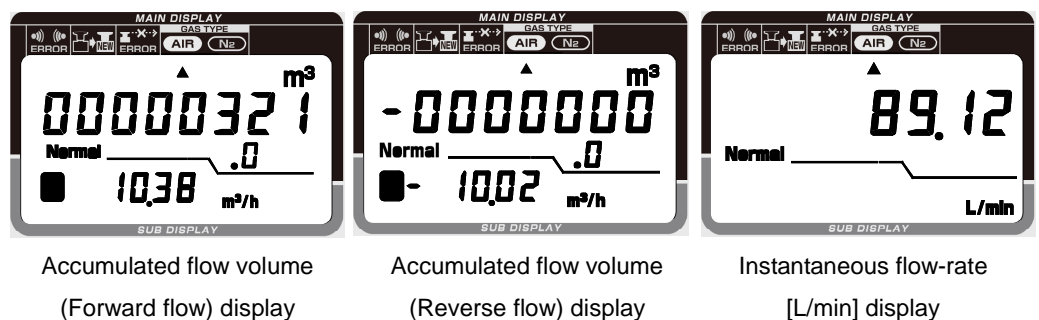

Fig. 7-5 Main display (where forward/reverse flow is selected)

B Switchover of the sub-display

Where the main display shows accumulated flow volume (Forward flow), trip accumulated flow volume, or accumulated flow volume (Reverse flow):

Each time SW2 is pressed, the display will cycle from Pressure to Temperature and then to instantaneous flow-rate. One minute after pressure or temperature is displayed, the display will automatically transition to the instantaneous flow-rate display.

Where the main display shows instantaneous flow-rate (L/min):

Only the unit is displayed.

2) Settings mode

[Overview]

This mode allows you to set up your flow meter using button operations.

[Details]

See 2. Settings.

3) Test mode

[Overview]

This mode allows you to perform a simplified pipe leakage test by temporarily canceling the low flow cutoff.

[Details]

[1] Please use this mode under conditions where there is no flow. You can transition to test mode by pressing SW2 for 3 seconds in measuring mode, and this will allow you to measure very small flow-rates.

[2] While in the test mode, the unit in the sub-display ( $\text{m}^3/\text{h}$ , kPa,  $^{\circ}\text{C}$ , or L/min) will flash in 0.5 second intervals.

[3] You can select test mode times of either 3 minutes, 60 minutes, or unlimited using the setting mode [F13]. The mode will transition to measuring mode once the set time elapses or by pressing SW2 for 3 seconds or longer in test mode.

[4] If the flow-rate value in the instantaneous flow-rate display is +0.1 or larger, there is a possibility\* of a leakage downstream of the meter.

[5] If the flow-rate value in the instantaneous flow rate display is -0.1 or smaller, there is a possibility\* of a leakage upstream of the meter.

\*Possibility: Please note that this is strictly a possibility as the displayed value also accounts for zero flow-rate offset, internal convection and other factors.

[6] The instantaneous flow-rate display in test mode is rounded to the second decimal point.

Examples) Display: 0.00 [ $\text{Nm}^3/\text{h}$ ] Actual: 0 to 0.004 [ $\text{Nm}^3/\text{h}$ ]

Display: -0.00 [ $\text{Nm}^3/\text{h}$ ] Actual: -0.004 to 0 [ $\text{Nm}^3/\text{h}$ ]

## **8. Processes during power outages (external power supply specification: D, RS485 output specification: R)**

### 1) Power outage detection

The meter determines a drop in power supply voltage to  $18\pm 1.1V$  or lower as a power outage, and performs the following operations:

- Save the accumulated flow volumes.
- Terminate measuring and output operations.
- Turn off the LCD display.

### 2) Recovering from a power outage

The meter performs the following operations once the power supply voltage recovers to  $18.8\pm 1.1V$  or greater:

- LCD display turns on.
- Resumes measuring and output operations (Measurements are resumed using the accumulated flow volumes that was saved at the time the power outage was detected.)

## 9. Specifications

Model	External power supply specification		TRX25D-C(N)/5P	TRX32D-C(N)/5P	TRX40D-C(N)/5P	TRX50D-C(N)/5P	TRX65D-C(N)/5P	TRX80D-C(N)/5P
	Built-in battery specification		TRX25B-C(N)/5P	TRX32B-C(N)/5P	TRX40B-C(N)/5P	TRX50B-C(N)/5P	TRX65B-C(N)/5P	TRX80B-C(N)/5P
	RS485 output specification		TRX25R-C(N)/5P	TRX32R-C(N)/5P	TRX40R-C(N)/5P	TRX50R-C(N)/5P	TRX65R-C(N)/5P	TRX80R-C(N)/5P
Nominal diameter			25A	32A	40A	50A	65A	80A
Power supply	External power supply specification RS485 output specification		24VDC±10%, Power consumption 1.5W or less					
	Built-in battery specification		Lithium battery Battery life 10 years (at an ambient temperature of 20°C)					
Fluid to measure			Air (primarily factory-supplied air), or nitrogen (The setting can be changed on the site.)					
Conversion	Normal conversion		Flow-rate at 0°C and 1 atmospheric pressure obtained by converting actual flow rate					
	Standard conversion		Flow rate converting from actual flow rate at the specified temperature (set to the flow meter) and 1 atmospheric pressure.					
Fluid temperature and humidity			-10 to 60°C, 90%RH or less					
Operating pressure			0MPa to less than 1MPa (Gauge pressure)					
Flow rate range (actual flow-rates)			±0.6 to 35m <sup>3</sup> /h	±1.1 to 65m <sup>3</sup> /h	±1.3 to 80m <sup>3</sup> /h	±2.5 to 150m <sup>3</sup> /h	±4 to 240m <sup>3</sup> /h	±5 to 300m <sup>3</sup> /h
Flow-rate measurement accuracy	±2%R.D.		±3.5 to 35m <sup>3</sup> /h	±6.5 to 65m <sup>3</sup> /h	±8 to 80m <sup>3</sup> /h	±15 to 150m <sup>3</sup> /h	±24 to 240m <sup>3</sup> /h	±30 to 300m <sup>3</sup> /h
	±5%R.D.		±0.6 to 3.5m <sup>3</sup> /h	±1.1 to 6.5m <sup>3</sup> /h	±1.3 to 8m <sup>3</sup> /h	±2.5 to 15m <sup>3</sup> /h	±4 to 24m <sup>3</sup> /h	±5 to 30m <sup>3</sup> /h
Low flow cutoff			±0.1m <sup>3</sup> /h	±0.2m <sup>3</sup> /h	±0.2m <sup>3</sup> /h	±0.4m <sup>3</sup> /h	±0.6m <sup>3</sup> /h	±0.8m <sup>3</sup> /h
Normal conversion accuracy			±2.5%R.D (at 500 kPa, 25°C)					
Display (switchover with buttons)	Type		LCD (with unit, measured fluid, and aberration displays) *Aberration display: flow-rate measurement aberration, pressure aberration, temperature aberration, communication circuit aberration, external memory aberration, battery voltage reduction (built-in battery specification), timing of flow meter replacement (built-in battery specification)					
	Main Display Note 1	Forward flow display mode	Accumulated flow volume: 00000000.0 [m <sup>3</sup> (normal)] Nine digits Trip accumulated flow volume: 0000000.0 [m <sup>3</sup> (normal)] Eight digits Instantaneous flow-rate: 00000.00 [L/min (normal)] Seven digits					
		Forward/reverse flow display mode	Accumulated flow volume: 00000000.0 [m <sup>3</sup> (normal)] Nine digits Accumulated flow volume (reverse flow): -0000000.0 [m <sup>3</sup> (normal)] Eight digits Instantaneous flow-rate: 00000.00 [L/min (normal)] Seven digits					
	Sub-display		Instantaneous flow-rate [m <sup>3</sup> /h (normal)]: 000.00 (smaller than 1000) Five digits, 00000 (10000 or larger) Five digits *Note 1 Pressure (kPa): 0000.0 Five digits, Temperature (°C): 00.0 Three digits					
	Reset function		Reset of all accumulated values, reset to standard factory delivery settings (resettable on the site)					
Output	External power supply specification Built-in battery specification	Current output		4-20mA (±0.1mA), load resistance 400 ohms or smaller, upper limit output current 22mA Selected from instantaneous flow-rate, pressure, and temperature. (The setting can be changed on the site.) Note) For the built-in battery specification, an additional power supply (24VDC±10%) is required. Output range (4-20mA): Instantaneous flow-rate [m <sup>3</sup> /h (normal)] 0-□□□□□ (forward flow display mode), -□□□□□-□□□□□ (forward/reverse flow display mode) □□□□□ represents a value that is set with buttons. Pressure: 0 to 1000kPa, Temperature: -10 to 65°C (fixed value)				
		Contact output	Output 1	Unit pulse (forward flow)				
			Output 2	Output is selected with buttons from unit pulse (reverse flow), flow-rate upper/lower limit alarm, main unit aberration, and electronic statement.				
	RS485 output specification	Common specifications	Nch open drain output 2 channels: maximum load: 24VDC, 50mA Output mode: Duty (35 to 65%, maximum frequency: 10Hz) Or one shot (ON time: Selected from 50, 100, 125, 250, 500ms) *Note 2) (The setting can be changed on the site.) Pulse output unit 100L(normal)/P, 1000L(normal)/P Note 1					
			Current output	Same with the external power supply specification and the built-in battery specification				
		Contact output	Output 1	Nch open drain output 1 channel: maximum load: 24VDC, 50mA Output mode: Duty (35 to 65%, maximum frequency: 10Hz) or one shot (ON time: Selected from 50, 100, 125, 250, 500ms *Note 2) (The setting can be changed on the site.) Pulse output unit 100L(normal)/P, 1000L(normal)/P Note 1				
			Communication *Note 3	1 channel: Compliant with RS485 Modbus/RTU Communication bit rate: Selected with buttons from 9600, 19200, 38400, 57600, 115200bps.				
Connection			Rc1	Rc1-1/4	Wafer (tightened between JIS10K flanges)			
Installation orientation			Horizontal (LCD display faces upward), or vertical					
Gas touching materials			Aluminum alloy, PPS, fluorosilicone rubber, etc.					
Weight			1.5kg	1.4kg	1.0kg	1.2kg	1.4kg	1.7kg
Installation location			Indoor, outdoor (protection grade compliant with IP64)					
Storage temperature			-20 to 70°C, non-condensing					

\*Note 1) With the setting of actual flow-rate measurement, the number of digits of accumulated flow volume display, the number of digits of instantaneous flow-rate display, and the unit of pulse output are different.

\*Note 2) Some units cannot be selected depending on the nominal diameter. Refer to Table 2-2 Table of output pulse unit selections on page 11.

\*Note 3) The communication specifications can be downloaded from our product website.

\*Piping conditions: 25A/32A: 20D or longer on the upstream side, 5D or longer on the downstream side (20D or longer for both the upstream and downstream sides when using the product in forward/reverse flow display mode)  
40A or larger: 10D or longer on the upstream side, 5D or longer on the downstream side (10D or longer for both the upstream and downstream sides when using the product in forward/reverse flow display mode)  
For details, please contact our branch/sales office.

Table 9-1 Normal flow-rate conversion values (Nm<sup>3</sup>/h) [Conversion examples]

	Pressure (MPa)	0 (atmospheric pressure)		0.5		0.7		0.98	
	Temperature (°C)	0	30	0	30	0	30	0	30
TRX25	0.6 (m <sup>3</sup> /h)	0.6	0.5	3.6	3.2	4.7	4.3	6.4	5.8
	35 (m <sup>3</sup> /h)	35	32	210	190	280	250	370	330
TRX32	1.1 (m <sup>3</sup> /h)	1.1	1.0	6.5	5.9	8.7	7.8	12	11
	65 (m <sup>3</sup> /h)	65	59	390	350	510	460	690	630
TRX40	1.3 (m <sup>3</sup> /h)	1.3	1.2	7.7	7.0	10	9.3	14	13
	80 (m <sup>3</sup> /h)	80	72	470	430	630	570	850	770
TRX50	2.5 (m <sup>3</sup> /h)	2.5	2.3	15	13	20	18	27	24
	150 (m <sup>3</sup> /h)	150	135	890	800	1180	1070	1600	1440
TRX65	4 (m <sup>3</sup> /h)	4.0	3.6	24	21	32	29	43	39
	240 (m <sup>3</sup> /h)	240	220	1420	1280	1900	1710	2560	2310
TRX80	5 (m <sup>3</sup> /h)	5.0	4.5	30	27	40	36	53	48
	300 (m <sup>3</sup> /h)	300	270	1780	1600	2370	2140	3200	2880

## 10. Dimension drawing

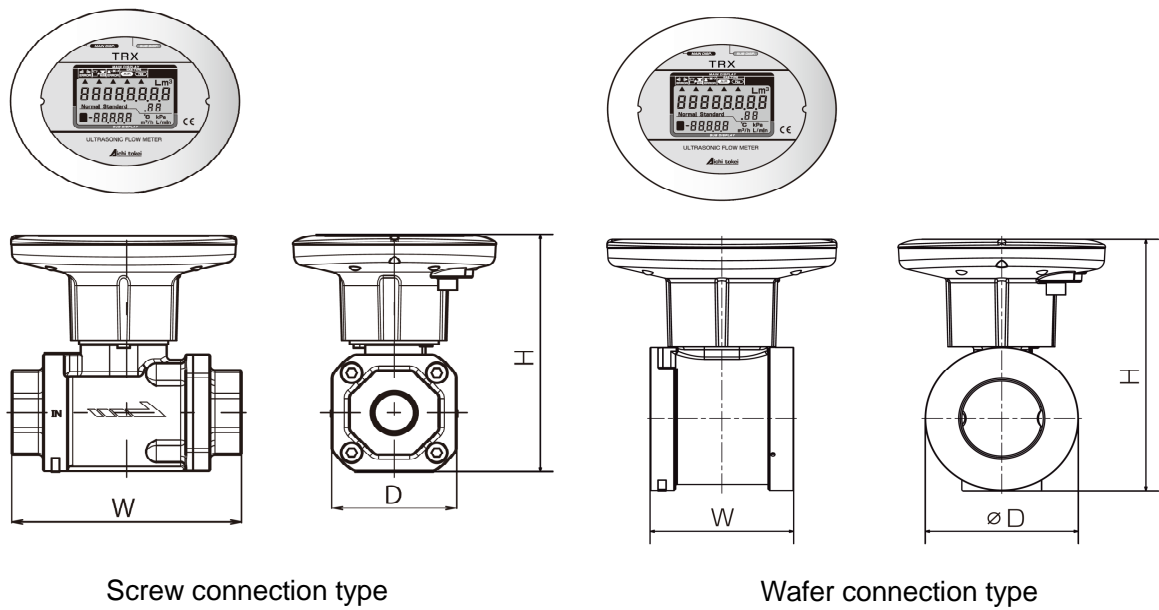



Fig. 10-1 Dimension drawing

Unit: mm

Nominal diameter	W	H	D	Connection with piping
25A	147	162	80	Screw
32A	147	162	80	
40A	76	163	81	Wafer
50A	90	176	96	
65A	108	197	117	
80A	117	220	126	

## 11. Troubleshooting

If you encounter any problems that cannot be resolved by taking the steps described below, please contact your nearest Aichi Tokei Denki branch or sales office.

	Phenomenon	Possible cause	Remedial action	Reference page
Settings	Even operating the buttons, unable to set a settings value.	Attempting to set a value that is outside the range of settable values.	Check to see that the kind of gas (air or nitrogen) indicator does not light at the time of settings mode. If this indicator lights, this is indication of attempting to set a value outside the range of settable values.	10
Installation	The measurement aberration indicator lights. 	Using a fluid other than air or nitrogen.	Check all reminders regarding specifications and installation.	5 18 24 31
		Using the meter outside its range of specifications (such as for installation conditions, pressure, temperature).		
		Foreign material is attached to the interior of the measurement pipe or ultrasonic sensors.		
There is a major source of electrical noise near the flow meter.				
Installation	It starts up but does not start accumulation immediately.	Carrying out adjustments due to pressure fluctuations.	Check to see if the partition line between the main and sub-displays is flickering. If it is, it means that the meter is undergoing adjustments for pressure fluctuations. This should typically complete in about 1 minute after which accumulation should begin.	/
	The instantaneous flow-rate shows a negative value.	The direction of the fluid flow and the flow direction of the meter are opposite of each other.	Check to see that the arrow on the surface of the flow meter is pointing in the direction of the fluid flow.	
Wiring connection	Unable to establish communication.	The communication cable is connected in +/- reverse.	Connect the cable correctly.	21
	Pulses are counted incorrectly.	The pull-up resistor is too large.	Check the signal receiver's specified ON current and select an appropriate pull-up resistor.	23
		The pull-up resistor is too small.		
	The current value of the 4-20mA output is too small.	The one-shot pulse ON time is equal to or smaller than the signal receiver's minimum input signal width.	Make sure to set the one-shot pulse ON time sufficiently large enough for the signal receiver's minimum input signal width.	23
		A load resistor of 400 ohms or greater has been connected.	Use a load resistance of no greater than 400 ohms.	22
		The setting value for the analog output FS flow-rate is too large.	Set an appropriate analog output FS flow-rate [F2] to suit your needs.	10
Unable to establish communication.	The communication intervals are short (The communication bit rate is high).	Adjust the intervals to the communication specification of the connected receiving device.	4	
	The maximum number of units that can be connected is exceeded.	Maximum number of units that can be connected 115200 bps: up to 8 units 9600 to 57600 bps: up to 31 units *For details, refer to the communication specifications.	/	
	The receiver that is used cannot receive RS485 communication.	Connect a receiver that can receive RS485 signals.		31



	Phenomenon	Possible cause	Remedial action	Reference page
After start operation	Sub-display flickers (pressure and instantaneous flow-rate)	The working pressure range has been exceeded.	Check to see that the operating pressure falls between 0 to 1MPa (Gauge pressure).	25 31
		Pressure sensor failure	Contact your nearest Aichi Tokei Denki branch or sales office.	
	Sub-display flickers (temperature and instantaneous flow- rate)	The operating temperature range has been exceeded.	Check to see that the operating temperature falls between -20°C and 70°C.	25 31
		Gas other than air or nitrogen is being used.	Do not use gases other than air or nitrogen.	5 31
	The instantaneous flow-rate appears to be fluctuating.	The pressure fluctuates frequently.	This is normal.	
		A pressure governor is installed near the flow meter.	This is normal. Installation of the meter farther away from the pressure governor is recommended to take accurate measurements.	16
	The instantaneous flow-rate does not fall to zero even there is no flow.	The fluid is convecting in the pipe.	This is normal.	
		Test mode is on.	Check to see that the value unit on the sub-display is not flickering.	29
	The instantaneous flow-rate is too large.	The straight section of the pipe is not long enough.	Please make sure to properly install straight pipe sections up and downstream of the meter to suit your specific piping conditions.	15 16
		It shows the normal flow rate display.	Check to see that the correct value unit for the application is used.	10 31
	The instantaneous flow rate does not seem to change.	There is excessive flow rate.	Use the meter within the scope of its specifications.	31
	The instantaneous flow rate is too small.	The straight section of the pipe is not long enough.	Please make sure to properly install straight pipe sections up and downstream of the meter to suit your specific piping conditions.	15 16
		The display shows the Actual flow-rate.	Check to see that the correct value unit for the application is used.	10 31
	The partition line is flickering.	Carrying out adjustments due to pressure fluctuations.	If it is, it means that the meter is undergoing adjustments for pressure fluctuations. This should typically complete in about 1 minute. (The partition line may also flicker momentarily during other actions, such as when a valve is opened or closed)	
	There is no "0" displayed in the upper most digit of the Accumulated flow volume.	The display is set to trip accumulated flow volume display.	This is normal. Refer to the page indicated to the right to revert to accumulated flow volume (forward flow) or accumulated flow volume (reverse flow) display.	27

memo

## ○ Warranty and after-sale service (valid only in Japan)

### 1) Warranty period

For the period of one year after purchase, in case of a failure that is explicitly attributable to our manufacturing process, we exchange the product for free.

### 2) Scope of warranty

The followings are not included in the scope of warranty.

- Failure caused by force majeure, such as natural disaster, etc.
- Disassembly or alteration of the product.
- Failure caused by mishandling.
- Failure caused by use in excess of the scope of the specifications (environment, etc.)
- Other cases determined to be not attributable to our responsibility

The warranty here means the warranty for our product alone and does not cover damages (damage(s) to other properties than our product, lost profits, opportunity losses, etc.) caused to you by a failure of our product.

### 3) Requesting for service

Regardless of whether or not your warranty has expired, please contact nearest our branch or sales office with the product name, model (TRX [nominal diameter] [power supply specification]-[kind of gas]/5P), construction work number, serial number, any options if used, and a detailed description of the failure.



### 4) Precautions for long-term use

[Designed standard operating period] 10 years

The designed standard operating period is the standard period for which the product can be used after installation without a safety issue arising from ageing degradation based on the standard conditions (ambient temperature 20°C, ambient humidity 65%RH).

When the product is used past the designed standard operating period, safety issues of the product itself may arise, such as deterioration of the waterproof and dustproof properties due to ageing degradation, smoking from, ignition of, or electric shock from the product.

When the designed standard operating period has passed, carefully check for abnormalities with the product when you use it, and consider replacement.

The designed standard operating period is different from the warranty period. The designed standard operating period does not warrant that no general failures would occur.



# Aichi Tokei Denki Co., Ltd.

1-2-70 Chitose, Atsuta-ku, Nagoya, Aichi Prefecture 456-8691 JAPAN

URL:<http://www.aichitokei.co.jp>

For questions, please contact our branch / sales office nearby.

---

Sapporo Branch	TEL(011)642-9500	Nagoya Branch	TEL(052)661-5852
Kushiro Sales Office	TEL(0154)23-7859	Kanazawa Sales Office	TEL(076)252-1942
Sendai Branch	TEL(022)258-1181	Shizuoka Sales Office	TEL(054)237-7168
Aomori Sales Office	TEL(017)738-7531	Nagano Sub-branch office	TEL(026)254-5677
Morioka Sales Office	TEL(019)646-8836	Osaka Branch	TEL(06)6305-9052
Tokyo Branch	TEL(03)3209-0631	Hiroshima Sales Office	TEL(082)292-8289
Yokohama Sales Office	TEL(045)661-1491	Takamatsu Sales Office	TEL(087)851-6664
Chiba Sales Office	TEL(03)5658-1320	Okayama Sales Office	TEL(086)207-6828
Omiya Sales Office	TEL(048)668-0131	Fukuoka Branch	TEL(092)534-2050
Niigata Sub-branch	TEL(025)282-5591	Kagoshima Sales Office	TEL(099)254-7877
		Miyazaki Sub-branch office	TEL(0985)24-2279
		Okinawa Sub-branch office	TEL(098)860-9792
		Overseas Business Division	TEL(052)661-5150

Ver. 4  
2016.09